



SPECIFICATION SHEET: WHPS2-UNV-T8-PS

This Is An Original Product From Fulham Co., Inc.

Description: WORKHORSE Specifier Grade Series Electronic Ballast, Drop In Replacement For Magnetic Ballast, Parallel Lamp Operation, THD Less Than 10%

This Ballast Will Operate Following Lamps:

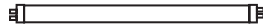

F32T8/25, F32T8/28, F32T8/30,
FBO28T8, FBO31T8, FBO32T8, F32T8

ELECTRICAL DATA

INPUT VOLT	120V ± 10%, 50/60Hz						
LAMP WATTS/TYPE	F32T8/25	F32T8/28	F32T8/30	FBO28T8	FBO31T8	FBO32T8	F32T8
LAMPS OPERATED	2 (TWO)						
INPUT WATTS	50	52	54	52	55	57	57
LINE CURRENT	0.42	0.44	0.45	0.44	0.46	0.48	0.48
POWER FACTOR	≥ 0.98	≥ 0.98	≥ 0.98	≥ 0.98	≥ 0.98	≥ 0.98	≥ 0.98
BALLAST FACTOR	1.00	0.90	0.90	0.90	0.88	0.88	0.88
BALLAST EFFICACY FACTOR	2.00	1.73	1.67	1.73	1.62	1.54	1.54
THD	≥ 10%	≥ 10%	≥ 10%	≥ 10%	≥ 10%	≥ 10%	≥ 10%
CURRENT CREST FACTOR	≥ 1.7						
EMI/RFI COMPLIANCE	FCC PART 18-A (NON-CONSUMER)						
SOUND RATING	"A"						
BALLAST TYPE	PROGRAMMED START						
VOLTAGE TRANSIENTS	ANSI C82.11-1993						
INPUT/PROTECTION	INHERENT THERMAL PROTECTION						
OUTPUT/PROTECTION	-						
MIN. STATING TEMP.	-18°C (0°F)						
MAX. CASE TEMP.	90°C (194°F)						
TYPE "HL" APPROVAL	APPROVED FOR HAZARDOUS LOCATION						
TYPE "CC" APPROVED	APPROVED						
APPROVALS/CLASS	UL/cUL LISTED, CLASS P, 1 OUTDOOR						
REMOTE MOUNTING	18 FT MAX. LEAD LENGTH, 18 AWG						

MECHANICAL DATA

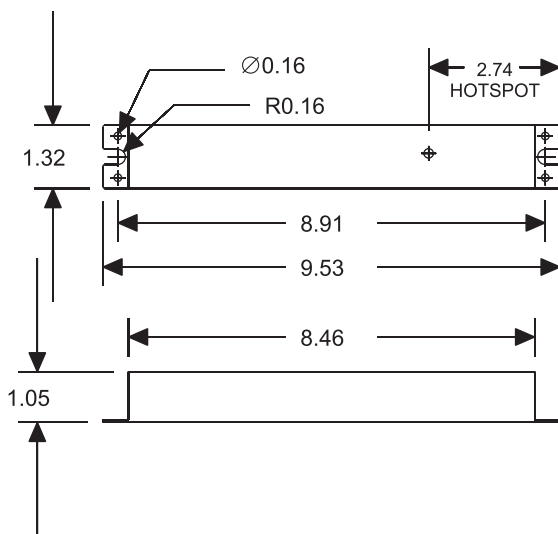

WIRING DIAGRAMS

WIRE	BLACK	WHITE	RED	BLUE	YELLOW	BROWN
LENGTH-INCHES	25±1"	25±1"	29±1"	29±1"	45±1"	-

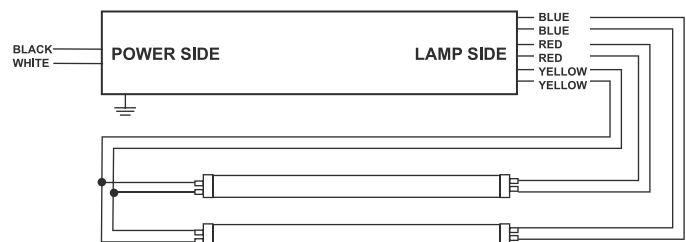

NOTE: This Ballast Must Be Grounded.

Fulham extends a limited warranty only to the original purchaser or to the first user for a period of 5 years from the date of manufacture when properly installed and operated under normal conditions of use. For complete terms and conditions, please reference the Fulham product catalog (www.fulham.com)
Due to a program of continuous improvement, Fulham reserves the right to make modifications or variations in design or construction to the equipment described.



SPECIFICATION SHEET: WHPS2-UNV-T8-PS

This Is An Original Product From Fulham Co., Inc.

Description: WORKHORSE Specifier Grade Series Electronic Ballast, Drop In Replacement For Magnetic Ballast, Parallel Lamp Operation, THD Less Than 10%

This Ballast Will Operate Following Lamps:

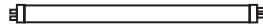

F32T8/25, F32T8/28, F32T8/30,
FBO28T8, FBO31T8, FBO32T8, F32T8

ELECTRICAL DATA

INPUT VOLT	230V ± 10%, 50/60Hz						
LAMP WATTS/TYPE	F32T8/25	F32T8/28	F32T8/30	FBO28T8	FBO31T8	FBO32T8	F32T8
LAMPS OPERATED	2 (TWO)						
INPUT WATTS	49	51	53	51	54	56	56
LINE CURRENT	0.22	0.23	0.24	0.23	0.24	0.25	0.25
POWER FACTOR	≥ 0.97	≥ 0.97	≥ 0.97	≥ 0.97	≥ 0.97	≥ 0.97	≥ 0.98
BALLAST FACTOR	1.00	0.90	0.90	0.90	0.88	0.88	0.88
BALLAST EFFICACY FACTOR	2.04	1.76	1.70	1.76	1.66	1.56	1.56
THD	≥ 10%	≥ 10%	≥ 10%	≥ 10%	≥ 10%	≥ 10%	≥ 10%
CURRENT CREST FACTOR	≥ 1.7						
EMI/RFI COMPLIANCE	FCC PART 18-A (NON-CONSUMER)						
SOUND RATING	"A"						
BALLAST TYPE	PROGRAMMED START						
VOLTAGE TRANSIENTS	ANSI C82.11-1993						
INPUT/PROTECTION	INHERENT THERMAL PROTECTION						
OUTPUT/PROTECTION	-						
MIN. STATING TEMP.	-18°C (0°F)						
MAX. CASE TEMP.	90°C (194°F)						
TYPE "HL" APPROVAL	APPROVED FOR HAZARDOUS LOCATION						
TYPE "CC" APPROVED	APPROVED						
APPROVALS/CLASS	UL/cUL LISTED, CLASS P, 1 OUTDOOR						
REMOTE MOUNTING	18 FT MAX. LEAD LENGTH, 18 AWG						

MECHANICAL DATA

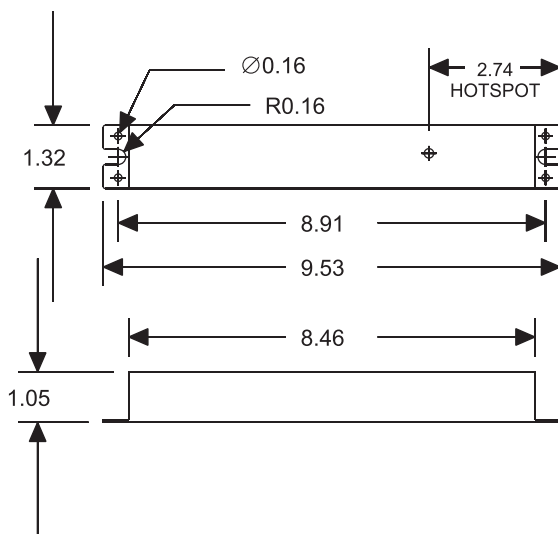

WIRING DIAGRAMS

WIRE	BLACK	WHITE	RED	BLUE	YELLOW	BROWN
LENGTH-INCHES	25±1"	25±1"	29±1"	29±1"	45±1"	-

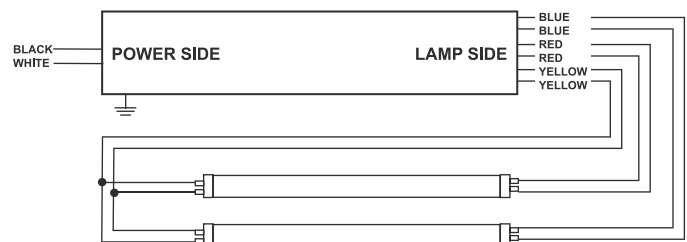

NOTE: This Ballast Must Be Grounded.

Fulham extends a limited warranty only to the original purchaser or to the first user for a period of 5 years from the date of manufacture when properly installed and operated under normal conditions of use. For complete terms and conditions, please reference the Fulham product catalog (www.fulham.com)
Due to a program of continuous improvement, Fulham reserves the right to make modifications or variations in design or construction to the equipment described.



SPECIFICATION SHEET: WHPS2-UNV-T8-PS

This Is An Original Product From Fulham Co., Inc.

Description: WORKHORSE Specifier Grade Series Electronic Ballast, Drop In Replacement For Magnetic Ballast, Parallel Lamp Operation, THD Less Than 10%

This Ballast Will Operate Following Lamps:

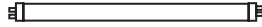

F32T8/25, F32T8/28, F32T8/30,
FBO28T8, FBO31T8, FBO32T8, F32T8

ELECTRICAL DATA

INPUT VOLT	277V ± 10%, 50/60Hz						
LAMP WATTS/TYPE	F32T8/25	F32T8/28	F32T8/30	FBO28T8	FBO31T8	FBO32T8	F32T8
LAMPS OPERATED	2 (TWO)						
INPUT WATTS	49	51	53	51	54	56	56
LINE CURRENT	0.18	0.19	0.20	0.19	0.20	0.21	0.21
POWER FACTOR	≥ 0.97	≥ 0.97	≥ 0.97	≥ 0.97	≥ 0.97	≥ 0.97	≥ 0.98
BALLAST FACTOR	1.00	0.90	0.90	0.90	0.88	0.88	0.88
BALLAST EFFICACY FACTOR	2.04	1.76	1.70	1.76	1.66	1.56	1.56
THD	≥ 10%	≥ 10%	≥ 10%	≥ 10%	≥ 10%	≥ 10%	≥ 10%
CURRENT CREST FACTOR	≥ 1.7						
EMI/RFI COMPLIANCE	FCC PART 18-A (NON-CONSUMER)						
SOUND RATING	"A"						
BALLAST TYPE	PROGRAMMED START						
VOLTAGE TRANSIENTS	ANSI C82.11-1993						
INPUT/PROTECTION	INHERENT THERMAL PROTECTION						
OUTPUT/PROTECTION	-						
MIN. STATING TEMP.	-18°C (0°F)						
MAX. CASE TEMP.	90°C (194°F)						
TYPE "HL" APPROVAL	APPROVED FOR HAZARDOUS LOCATION						
TYPE "CC" APPROVED	APPROVED						
APPROVALS/CLASS	UL/cUL LISTED, CLASS P, 1 OUTDOOR						
REMOTE MOUNTING	18 FT MAX. LEAD LENGTH, 18 AWG						

MECHANICAL DATA

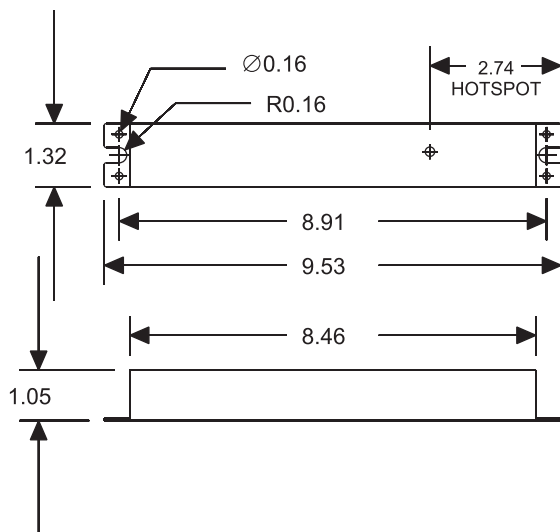

WIRING DIAGRAMS

WIRE	BLACK	WHITE	RED	BLUE	YELLOW	BROWN
LENGTH-INCHES	25±1"	25±1"	29±1"	29±1"	45±1"	-

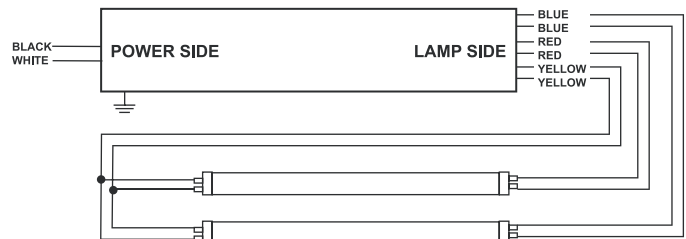

NOTE: This Ballast Must Be Grounded.

Fulham extends a limited warranty only to the original purchaser or to the first user for a period of 5 years from the date of manufacture when properly installed and operated under normal conditions of use. For complete terms and conditions, please reference the Fulham product catalog (www.fulham.com)
Due to a program of continuous improvement, Fulham reserves the right to make modifications or variations in design or construction to the equipment described.