



## SPECIFICATION SHEET : WH42-UNV-L

This Is An Original Product From Fulham Co., Inc

**Description : WORKHORSE Electronic Ballast.  
Parallel Lamp Operation.**

**\* This Ballast Will Operate The Following Lamp Types:  
CFQ/4P, CFTR/4P, T5, T6SL, T8, T8SL, CFT/4P, FT/4P, T9CR, T5CR, T5HO, T8HO, T10, T12, T12SL  
WHEN USED PER FULHAM's LAMP / BALLAST WIRING DIAGRAM.**

### ELECTRICAL DATA ( Universal,120 - 277V)

INPUT VOLT: 120V - 277V ± 10%, 50/60Hz	
LAMP TYPE AND NUMBER OF LAMPS	1 CFQ/4P, CFTR/4P, CFT/4P, T6SL, T8, FT/4P, T9CR, T5CR, T5HO, T8HO, T10, T12, T12SL. 2 CFQ/4P, CFTR/4P, T5, T8.
WIRING DIAGRAM #	REFER TO FULHAM's LAMP / BALLAST WIRING DIAGRAM.
POWER FACTOR	HIGH POWER FACTOR
THD	< 10% @ FULL POWER
EMI/RFI COMPLIANCE	FCC PART 18-A
SOUND RATING	"A"
BALLAST TYPE	INSTANT START
VOLTAGE TRANSIENTS	ANSI C82.11 - 1993 / C62.41
MIN. OPERATING TEMP	0 °C ( 32 °F )
MAX. CASE TEMP	70 °C ( 158 °F )
APPROVALS/CLASS	UL LISTED, CLASS " P ", 1 OUTDOOR
* NOTE:	PLEASE CONTACT FULHAM CUSTOMER SERVICES FOR PERTICULAR LAMP/BASLLAST SPECIFICATIONS.

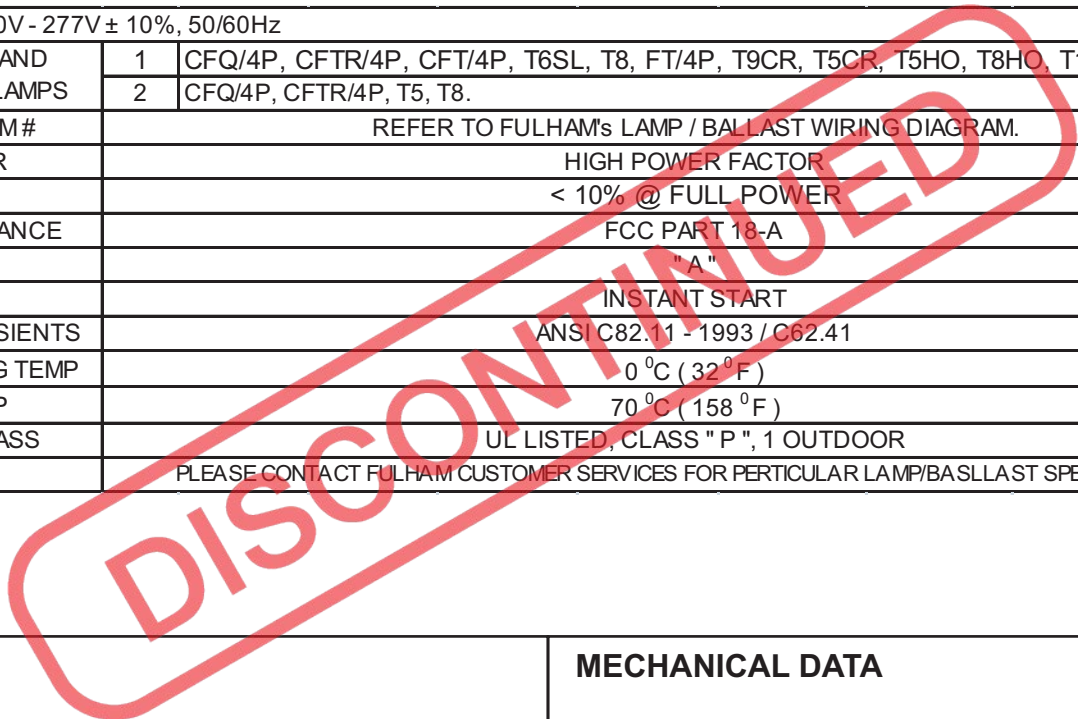

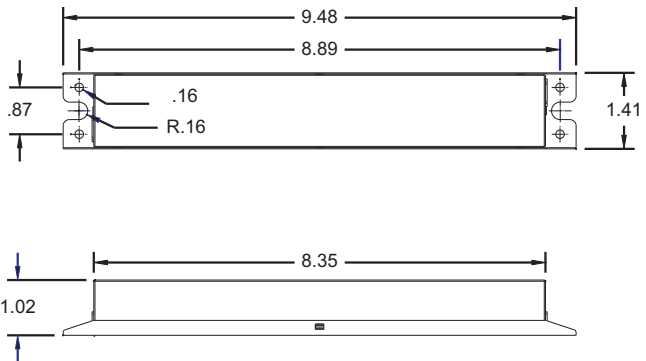
<p><b>IMAGE</b></p>  <p><b>NOTE :</b> This ballast case must be grounded</p> <table border="1" style="width: 100%; border-collapse: collapse; margin-top: 10px;"> <tr> <th style="width: 15%;">WIRE</th> <th style="width: 10%;">BLACK</th> <th style="width: 10%;">WHITE</th> <th style="width: 10%;">RED</th> <th style="width: 10%;">BLUE</th> <th style="width: 10%;">YELLOW</th> <th style="width: 10%;">BROWN</th> </tr> <tr> <td>LENGTH - INCHES</td> <td>18 ± 1"</td> <td>18 ± 1"</td> <td>36 ± 1"</td> <td>-</td> <td>36 ± 1"</td> <td>-</td> </tr> </table>	WIRE	BLACK	WHITE	RED	BLUE	YELLOW	BROWN	LENGTH - INCHES	18 ± 1"	18 ± 1"	36 ± 1"	-	36 ± 1"	-	<p><b>MECHANICAL DATA</b></p>  <p style="text-align: center; margin-top: 10px;">Where : L = Length, W = Width, H = Height</p>
WIRE	BLACK	WHITE	RED	BLUE	YELLOW	BROWN									
LENGTH - INCHES	18 ± 1"	18 ± 1"	36 ± 1"	-	36 ± 1"	-									

Fulham extends a limited warranty only to the original purchaser or to the first user for a period of 5 years from the date of manufacture when properly installed and operated under normal conditions of use. For complete terms and conditions, please reference the Fulham product catalog ([www.fulham.com](http://www.fulham.com))  
**Due to a program of continuous improvement, Fulham reserves the right to make modifications or variations in design or construction to the equipment described.**