



TMU125050CL8xxH



22" LINEARHO DC MODULE, 1250mA MAX CURRENT

- Extruded Aluminum material for thermal management
- Magnets pre-mounted, for ease of installation
- High lumen, high efficacy, suitable for DLC 6.0
- Accessories: Diffused lens and End-Caps available
- For use in UL Class 2 lighting systems
- Suitable for DLC applications: L70>60,000hrs / L90>60,000hrs
- Meets UL8750 recognized
- RoHS compliant
- The module is supplied by short circuit proof SELV controlgear

General Specifications

	4000K/80CRI	4000K/80CRI
Input Voltage ^①	33.1VDC	34.3VDC
Input Current ^①	700mA	1250mA(Max.)
Input Power ^①	23.2W	42.9W
Initial Lumens @4000K / 80CRI	4,646 lumens	8,078 lumens
Initial Lm/W @4000K / 80CRI	200 lm/W	188 lm/W
Beam Angle	120°	
CRI	80CRI Standard; 90CRI Optional	
Storage Temperature Range	-40°C to 100°C / -40°F to 212°F	
Operating Temperature Range (ta)	-40°C to 55°C / -40°F to 131°F	
Maximum Case Temperature (Tc)	L70: Tc max 105°C/ L90: Tc max 105°C	
Estimated Lumen Maintenance ^②	L70: >60,000Hrs / L90: >60,000Hrs	
Color Consistency	Binning per ANSI C78.377-2015 @ 25°C; 3 SDCM Typ.; 6 SDCM Max.	
Overall Size	22" x 1.73" x 0.39" (560mm x 44mm x 10mm)	
PCB Material / Thermal Conductivity	CEM-3 1.0W/mK	
Extruded Material / Finish	Aluminum/surface treatment with Anodic Oxidation	
LED Quantity	96pcs	
Module Weight	110g / 0.24lb.	
PCB Part Number	PTL004C01C3	
Magnets Quantity / Magnetic Force	2 / 2N (.45lbf) per magnet	
Maximum Screw Installation Torque	25 inch - ounces	
Connector Type	WAGO #744-392 (2 pin connector)	
Packaging: Master Carton	20pcs.	
Thermal Feedback	Not Available	
Safety/Compliance	cURus (File # E351548) Suitable for UL Class 2 Lighting Systems RoHS Compliant Dry and Damp Location CE (IEC 62031: 2008. AMD1: 2012, AMD2: 2014) SELV	
Energy Efficiency Label (EEI-Label)	C	
Warranty	5 years @ Max. Tc from the date of manufacture	

^①Nominal ratings. Performance based on Tc mod = 25°C. See thermal de-rating chart (pg. 3) for higher temperature operation.

^②TM-21 Reported Numbers



TMU125050CL8xxH



Electrical and Optical Specifications

LED Module Part Number	Number of LED	Input Current	Nom. Forward Voltage	Nom. Rated Power	Max. Fwd. Voltage	Max. Rated Power	Nom. Lum. Flux @4000K/80 CRI	Nom. Efficacy @4000K/80 CRI	Nom. Lum. Flux per foot @4000K/80CRI	Nom. Lum. Flux per string @4000K/80CRI
TMU125050CLxxxH (22")	96	200 mA	31.6 V	6.3 W	34 V	7 W	1340 lm	212 lm/W	731 lm/ft	168 lm/string
		250 mA	31.8 V	8.0 W	34 V	9 W	1677 lm	211 lm/W	915 lm/ft	210 lm/string
		300 mA	32.0 V	9.6 W	34 V	10 W	2013 lm	210 lm/W	1098 lm/ft	252 lm/string
		350 mA	32.2 V	11.3 W	34 V	12 W	2347 lm	209 lm/W	1280 lm/ft	293 lm/string
		400 mA	32.3 V	12.9 W	35 V	14 W	2680 lm	207 lm/W	1462 lm/ft	335 lm/string
		450 mA	32.5 V	14.6 W	35 V	16 W	3011 lm	206 lm/W	1643 lm/ft	376 lm/string
		500 mA	32.6 V	16.3 W	35 V	18 W	3341 lm	205 lm/W	1823 lm/ft	418 lm/string
		550 mA	32.7 V	18.0 W	35 V	19 W	3670 lm	204 lm/W	2002 lm/ft	459 lm/string
		600 mA	32.9 V	19.7 W	35 V	21 W	3997 lm	203 lm/W	2180 lm/ft	500 lm/string
		650 mA	33.0 V	21.4 W	35 V	23 W	4322 lm	202 lm/W	2358 lm/ft	540 lm/string
		700 mA	33.1 V	23.2 W	35 V	25 W	4646 lm	200 lm/W	2534 lm/ft	581 lm/string
		750 mA	33.2 V	24.9 W	36 V	27 W	4968 lm	199 lm/W	2710 lm/ft	621 lm/string
		800 mA	33.3 V	26.7 W	36 V	29 W	5288 lm	198 lm/W	2884 lm/ft	661 lm/string
		850 mA	33.4 V	28.4 W	36 V	31 W	5606 lm	197 lm/W	3058 lm/ft	701 lm/string
		900 mA	33.5 V	30.2 W	36 V	32 W	5922 lm	196 lm/W	3230 lm/ft	740 lm/string
		950 mA	33.6 V	32.0 W	36 V	34 W	6236 lm	195 lm/W	3402 lm/ft	780 lm/string
		1000 mA	33.8 V	33.8 W	36 V	36 W	6549 lm	194 lm/W	3572 lm/ft	819 lm/string
		1050 mA	33.9 V	35.6 W	36 V	38 W	6859 lm	193 lm/W	3741 lm/ft	857 lm/string
1100 mA	34.0 V	37.4 W	36 V	40 W	7167 lm	192 lm/W	3909 lm/ft	896 lm/string		
1150 mA	34.1 V	39.2 W	36 V	41 W	7473 lm	191 lm/W	4076 lm/ft	934 lm/string		
1200 mA	34.2 V	41.0 W	37 V	44 W	7777 lm	190 lm/W	4242 lm/ft	972 lm/string		
1250 mA*	34.3 V	42.9 W	37 V	46 W	8078 lm	188 lm/W	4406 lm/ft	1010 lm/string		

Luminous Flux De-Rating: CCT and CRI Multipliers

	2700K	3000K	3500K	4000K	5000K	5700K	6500K
CRI 80(R9> 0)	0.924	0.951	0.965	1.000	1.014	1.007	1.000
CRI 90(R9>50)	0.774	0.836	0.829	0.850	0.864	0.864	0.850

NOTES:

- 1) Performance based on Tc mod = 25°C. See thermal de-rating chart (pg. 3) for higher temperature operation
- 2) Standard lumen output and efficacy is calculated for standard options. Reference CCT & CRI vs Luminous Flux chart for lumen ratio calculation.
- 3) Specifications are subject to change without notice.
- 4) The LED DC Module can be configure with different LED chip quantities, series and parallel design configurations to meet a specific design requirement. Contact Fulham for further assistance.
- 5) * Indicates maximum rated current. Modules may be operated at a current less than or equal to this value, below the Tc rating.
- 6) 70CRI is NOT available.



TMU125050CL8xxH



Thermal Specifications

LinearHO Module

Storage Temperature Range	-40 to +100°C / -40 to +212°F
Operating Ambient Temperature Range (ta)	-40 to 55°C / -40 to 131°F
Maximum Case Temperature (Tc)	L70 = 105°C (221°F) / L90 = 105°C (221°F)

Thermal De-Rating:

Tc vs. Luminous Flux vs. Forward Voltage

Module Case Temperature (Tc)	Total Vf Multiplier	Luminous Flux Multiplier
25°C	1.000	1.000
30°C	0.998	0.995
35°C	0.996	0.990
40°C	0.994	0.985
45°C	0.992	0.979
50°C	0.990	0.974
55°C	0.988	0.968
60°C	0.986	0.962
65°C	0.985	0.956
70°C	0.983	0.950
75°C	0.981	0.944
80°C	0.979	0.938
85°C	0.977	0.931
90°C	0.975	0.925
95°C	0.974	0.918
100°C	0.972	0.911
105°C	0.970	0.904



TMU125050CL8xxH



Certification Chart

Classification	Model	TMU125050CL8xxH
		YES
		YES
		YES
Energy Efficiency Label (EEI-Label)		C
Suitable for UL Class 2 Lighting System		YES

Energy Star™ TM-21 Calculator Data

Tc Module	Reported L70	Reported L90
55°C	>60,000 Hrs	>60,000 Hrs
85°C	>60,000 Hrs	>60,000 Hrs
105°C	>60,000 Hrs	>60,000 Hrs

Tc Module	Calculated L70	Calculated L90
55°C	250,000 Hrs	77,000 Hrs
85°C	234,000 Hrs	70,000 Hrs
105°C	237,000 Hrs	71,000 Hrs

LED Lumen & Color Maintenance Data per LM-80 report and TM-21 Calculator

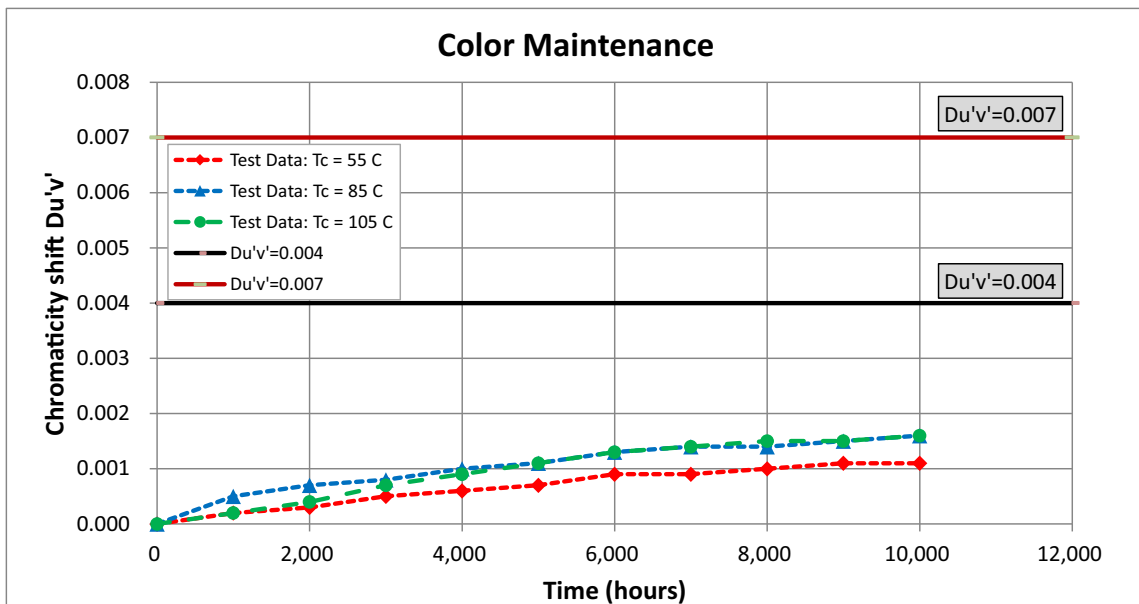
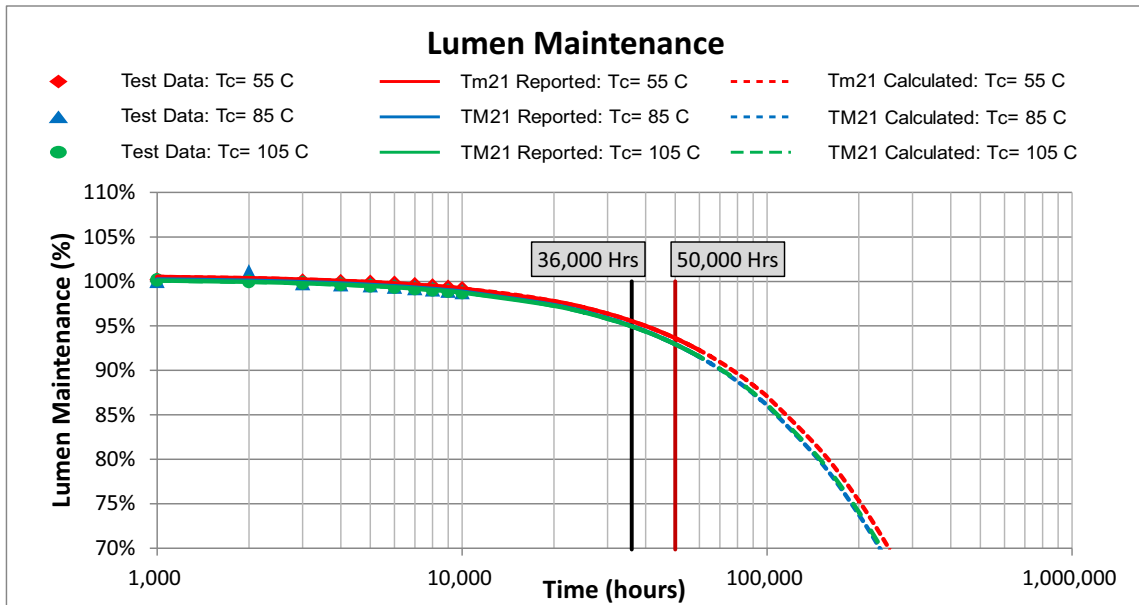



TMU125050CL8xxH



Mechanical Drawings

22"
[560mm]

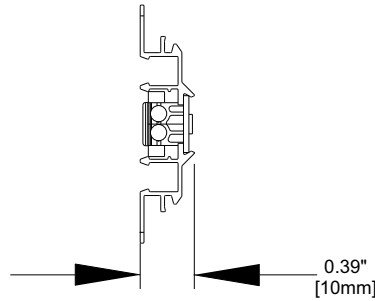

SIDE VIEW

Overall Dimensions	
Length	22" [560mm]
Width	1.73" [44mm]
Height	0.39" [10mm]

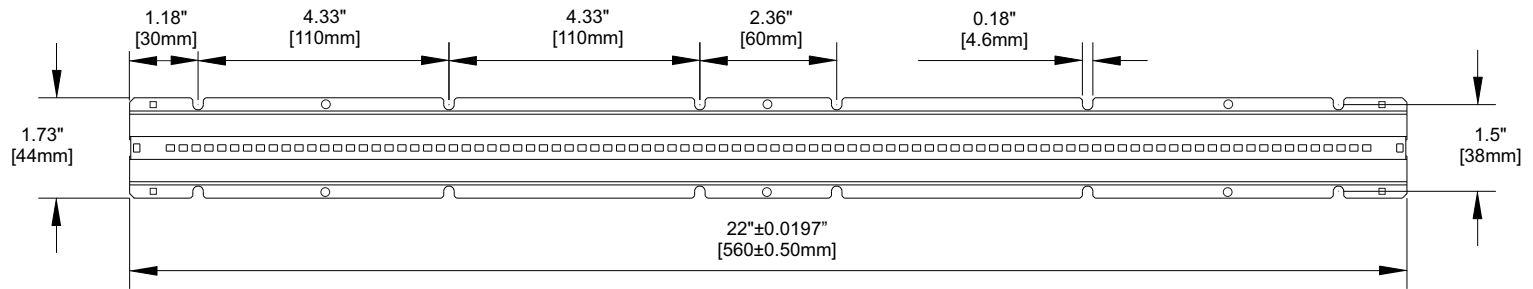

TOP VIEW

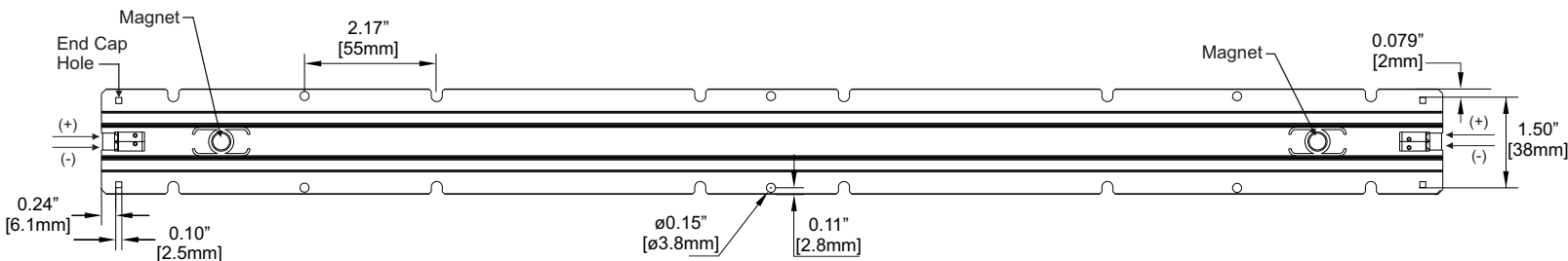

BOTTOM VIEW

Unmarked General Tolerance

- <4" [100mm]: ±0.0138" [±0.35mm]
- 4"~11.8" [100~300mm]: ±0.0197" [±0.5mm]
- >11.8" [300mm]: ±0.0236" [±0.6mm]
- HOLES: ±0.002" [±0.05mm]



TMU125050CL8xxH



Accessories

22" Diffuser Lens

Fulham Part Number: **22": TLE-OPT-120-004**

- White polycarbonate diffuser lens - 82% transmissivity at nominally rated currents.

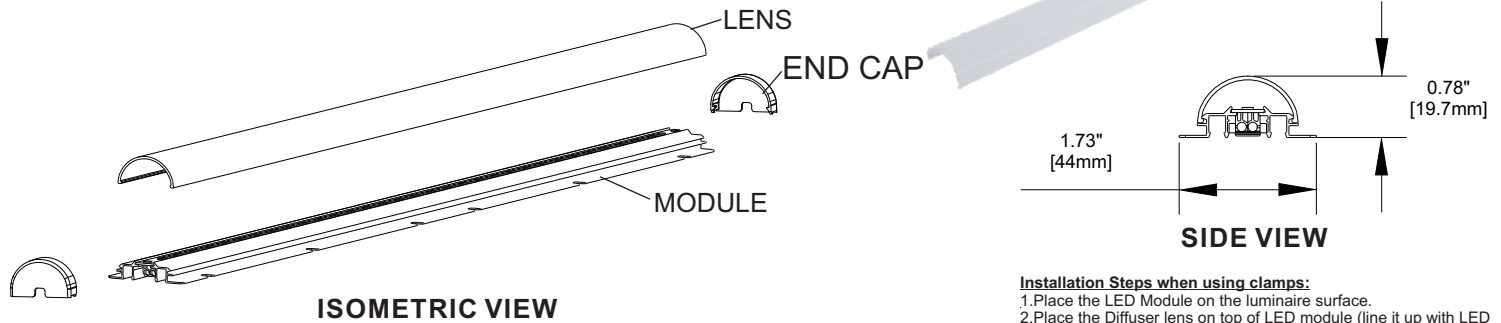

Installation Steps when using clamps:
 1. Place the LED Module on the luminaire surface.
 2. Place the Diffuser lens on top of LED module (line it up with LED module mounting edges).
 3. Push down to snap into place.

End Caps

Fulham Part Number: **TLE-OPT-120-020**

- White Polybutylene Terephthalate (PBT) end caps

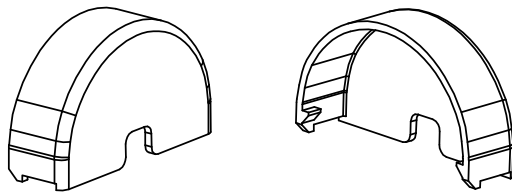

ISOMETRIC VIEW

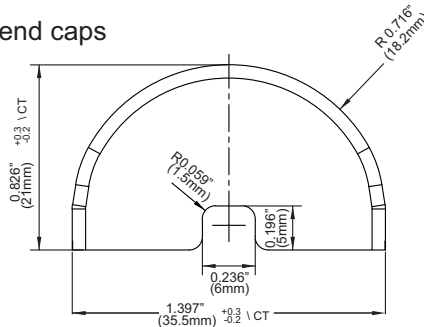

SIDE VIEW

Harness

TLC-HN02 (1 and 2 module connection)

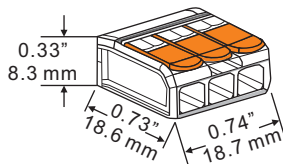
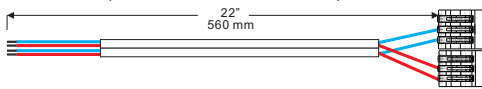

ISOMETRIC VIEW

TLC-HN04 (3 and 4 module connection)

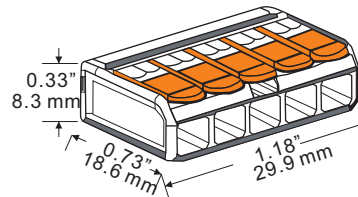
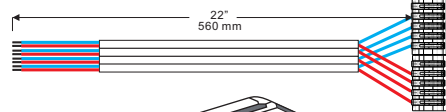

ISOMETRIC VIEW

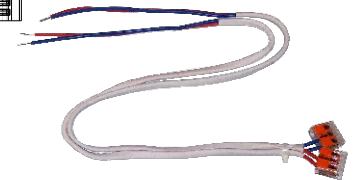

Interconnects

- Interconnect Type: WAGO Double pins to interconnect Modules (#2060-952/028-000)
- Approvals: cURus, UL 1977, and RoHS Compliant

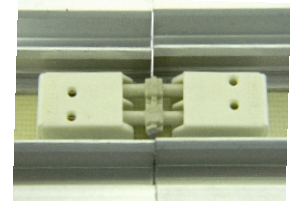

BOTTOM VIEW

NOTES:

- 1) Interconnects are NOT sold by Fulham.
- 2) Do not connect LinearHO Modules in parallel (end to end) if the current exceeds the maximum module rated current. This type of wiring would cause the pass-through current on the first module to exceed the rated current. This setup is in reference to wiring diagram #2 per Fulham's wiring diagram (see link on page #8). If the current is higher than the rated max, it is recommended to use wiring diagram #3.



TMU125050CL8xxH



Color and Binning

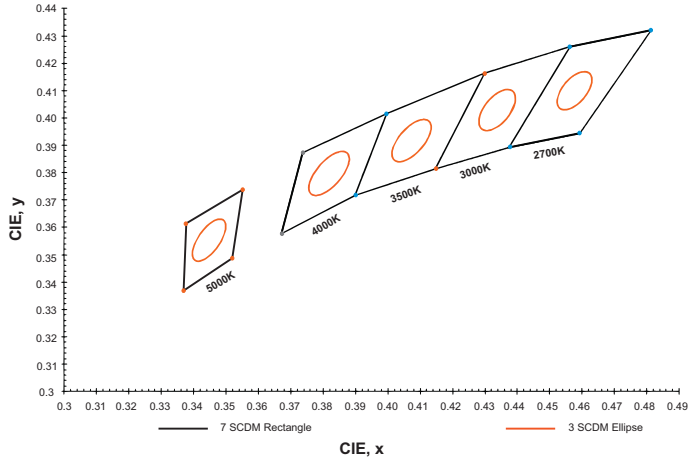

Optical Spectrum

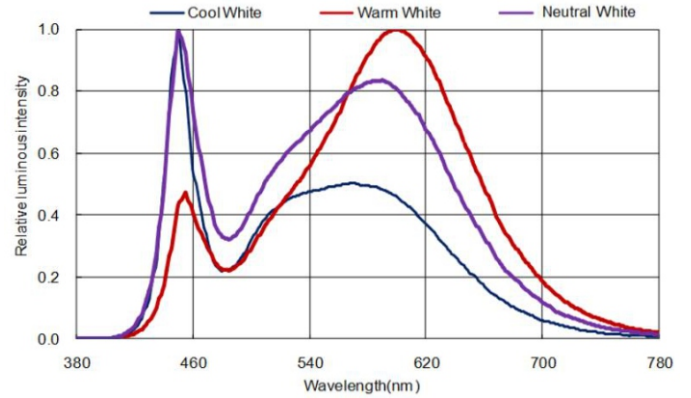

NOTES:

- 1) The Color and Binning and Optical Spectrum charts are for reference only. For more detailed info, contact factory.
- 2) Reference Seoul Chromaticity Diagram for Color and Binning. Binning per ANSI C78.377-2015 @ 25°C; 3 SDCM.
- 3) The Optical Spectrum values vary depending on product type and color rank.



TMU125050CL8xxH



Guidelines

Termination Notes

- Connector Type: WAGO #744-392 (2 pin push wire connector)
 - AWG: 20...16 solid wire
 - Strip length: 8...9mm / 0.31...0.35in
 - Connector Max amp. rating: 6 Amps.

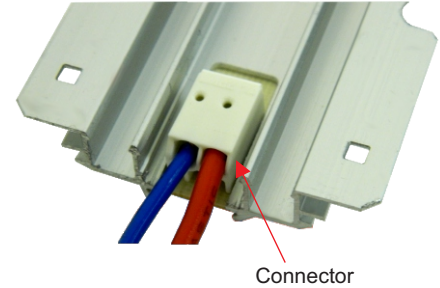

Fastening Notes

- If fastening by screw hole, use any screw with diameter less than 0.185 in (4.7mm). Use all available screw holes to ensure good contact between back side of module and mounting surface. Refer to max specified torque for installation. Suggested screw sizes: #6 or M4 Pan Head screw.
- If fastening using double-sided tape, start with clean, oil-free and dust-free surface. Peel backing and place LED module on mounting surface. Firmly press down on the module to ensure good adherence. Follow the double-side tape manufacturer's installation instructions.
- BJB P2F (Push-to-Fix) fixing elements for PCBs can be used to fasten LED modules to mounting surface. Reference BJB's website for ordering information and specific model to use: <http://www.bjb.com/index.php?pid=376706&lid=10>.

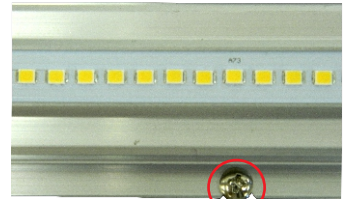

Environmental Rating / Conformal Coating

- The DC LinearHO Modules have been evaluated for use in dry or damp locations only. If used in wet locations, acceptability and the need for additional evaluation shall be determined in the end product.
- Fulham's LinearHO modules are available with conformal coating; made to order with MOQ and lead time will apply. The conformal coating is a silicone based material which is double sprayed on the module only (LEDs and PCB). Conformal coating is recommended for the following applications: near ocean where salt is present, constant moisture, refrigeration, continuously high humidity, or outdoor applications. An IP rating of IP64 or IP65 is achieved when the conformal coating is used, but other factors should be considered. Fulham still recommends the luminaire also meet an IP64/65 rating.

Electrostatic Sensitive Product (ESD)

- Fulham LED products should be handled with proper measures to protect against any potential ESD damage.
- When servicing, personnel should be ground and direct contact with LED should be avoided.

Thermal Management

- Proper thermal management should be employed to ensure life and reliability of product. Max Tc of module should not be exceeded.
- Use of thermal grease, paste, pad, or other material interface is highly recommended.

Polarity Notes

- DC Modules are polarity sensitive.
- Ensure that "positive" from LED Driver is connected to "positive" of LED modules and that "negative" from LED Driver is connected to "negative" of LED modules.
- Polarities of modules are marked with "+" for positive and "-" for negative.



TMU125050CL8xxH

UK CA CE c RoHS COMPLIANT

Part Number Matrix

T M U 125 050 CL 8 xx H

<u>Type</u> M = Module (UL Class 2)	<u>Control Type</u> U = None	<u>Input Current</u> 125 = 1250mA Max.	<u>Max. Power</u> 050 = 50W	<u>Shape</u> CL=Linear	<u>CRI</u> ⑧ 8 = 80 9 = 90	<u>Color Temperature</u> 27 = 2700K ③ 30 = 3000K ③ 35 = 3500K ③ 40 = 4000K ③ 50 = 5000K 57 = 5700K 65 = 6500K	<u>Option</u> H = High Efficacy ③ K = Conformal Coating (MTO)
---	---------------------------------	---	--------------------------------	---------------------------	----------------------------------	--	---

③ Standard Product offering (All other options are made to order with MOQ and lead time)
 ④ See page #8 for Conformal Coating information. Made to order (MTO).

Product Image: LinearHO Module

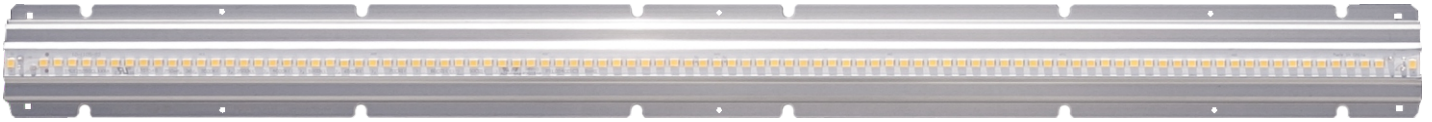

TOP VIEW

Packaging

Master Carton

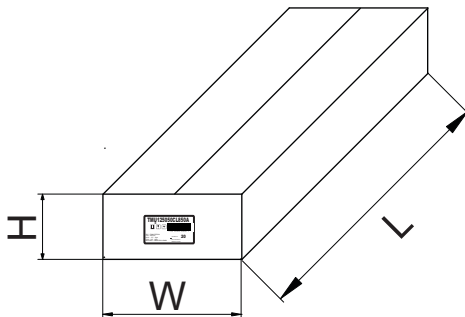

OUTER DIMENSION		
L	W	H
23.43"(595mm)	10.63"(270mm)	4.33"(110mm)
Net Weight	Gross Weight	QUANTITY
5.51 lbs. (2.5kg)	7.71 lbs. (3.5kg)	20pc.