

Model: TLM1612004/TLM1623004



Lamp Data:

Applications:

- Spot Lighting
- Architectural Lighting
- Retail Display Case
- Mood Lighting
- Track Lighting
- Commercial & Residential

Advanced Features:

- CE Approved
- Up to 70% Energy Savings: High Brightness Using Less Power
- Long Life LEDs
- Easy Installation
- Superior Heat Management
- Minimal UV and Heat Emission onto Lit Surface
- Environmentally Friendly: **No Lead, No Mercury**
- Durable Solid State Construction: **No Filaments To Break**

Lamp Specifications:

Input Power	4W
Diameter	1.95" (4.95 cm)
MOL	2.45" (6.22 cm)
Base	GU10
Input Voltage	120V/230V
Input Frequency	50Hz/60Hz
LED Type	CREE
Beam Angle	30°, 45°
LED Life Rating*	>35,000 Hours
Operation Temp.	-20°C to 40°C
IP Rating	30
Warranty	2 Years

*Based on LED LM-80 Data

Ordering Options:

Product Family	TL
Lamp Type	M16
Input Voltage	120 230
Wattage	04
Color Temperature	28 40 60
Beam Angle	30 45
Part Number Example	TLM16120044045

Photometric Specifications:

Color Temperature	CRI	Typical Output
Cool White (6000°K)	75	190 lm
Natural White (4000°K)	75	180 lm
Warm White (2800°K)	80	160 lm

Dimensions:

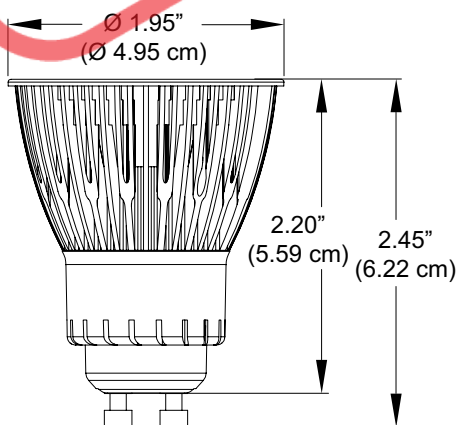

Beam Pattern: 30° Beam, 2800K

