

T1A1UNV150P-100C
INSTALLATION INSTRUCTIONS



IP65



- Built-in LED Driver
- Universal Voltage: 120-277VAC, 50/60Hz
- Output Wattage: 100W
- Output Current: 500-1500mA
- Output voltage range of 50-152VDC
- Long Case and Terminal
- IP65 Dry and Damp
- Suitable for Class I luminaire
- U-OUT 280V

This Driver Will Operate The Following LED Modules: Any LED module designed to accept input voltage range of 50-152VDC and can operate up to current of 500-1500mA.

General Specifications

Input Voltage	120-277VAC, 50/60Hz
Input Current	1.1A Max.
Input Power	116W
Power Factor	>0.9
THD	<20%
Driver Type	PROGRAMMABLE CONSTANT CURRENT DRIVER
Output Current	500-1500mA
Output Voltage Range	50-152VDC
Output Power	100W
Number of Output Channels	1 Channel
RFI/EMI	FCC Part 15B Consumer, EN55015
Output Type	Non Class 2
Ambient Operating Temperature Range	-40°C to 60°C (-40°F to 140°F)
Sound Rating	A
Input Surge Protection	Line-Neutral 4kV, Line & Neutral-Ground 6kV
Protections	Output Open Circuit Protection Overload Protection Over Temperature Protection
Service Life	50,000 hours
Approvals / Class	CLASS P

Mechanical Data

Tolerance=±0.02"[0.5mm]

Wire:18AWG1015
0.75mm²

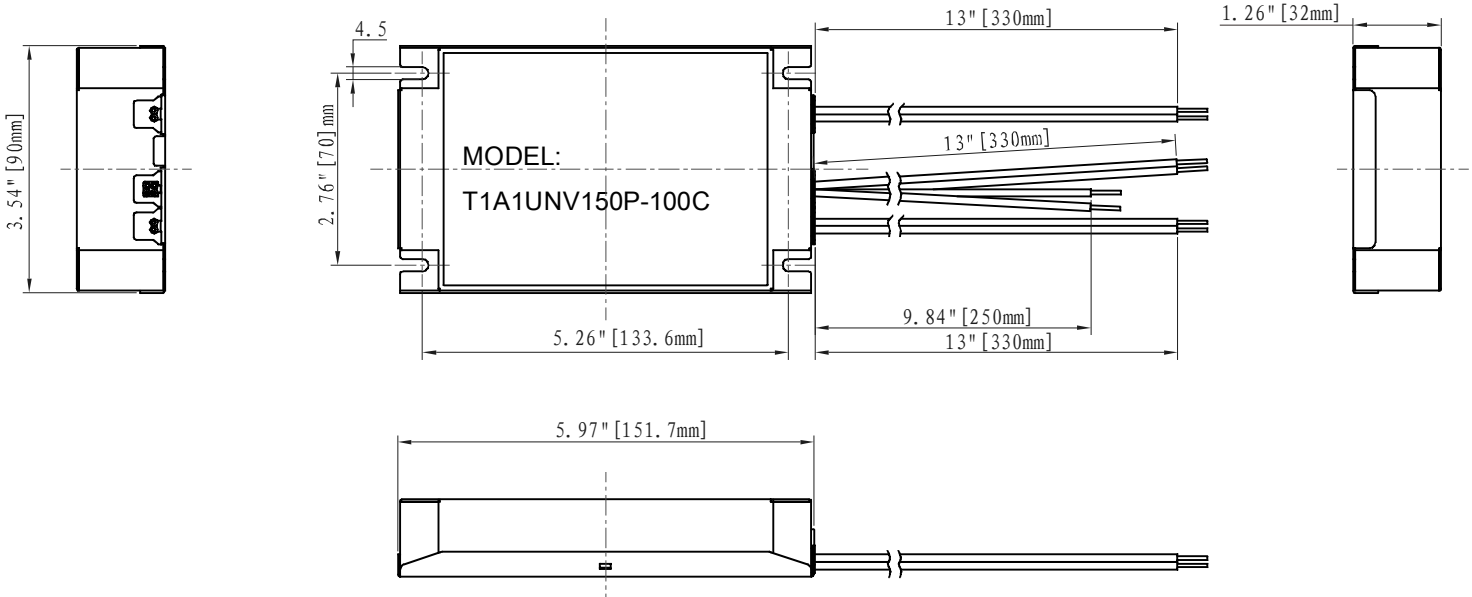

Fulham Head Quarters:
Fulham Co., Inc
12705 South Van Ness Ave.
Hawthorne, CA 90250
Local: (323) 779-2980, Fax: (323) 754-9060

Manufacturer:
North China
Fulham Electronic Co. Ltd.
No. 9 Xingchang Road, Nanshao Zhen Changping Science Park, Beijing, P.R. China

Fulham extends a limited warranty to the original purchaser or first user for a period of 5 years from the date of manufacture when properly installed and operated under normal conditions of use. The usage of appropriate series connected Surge Protection Device (SPD) is required in high risk applications. For complete terms and conditions, please refer to the Warranty Center at www.fulham.com. Specifications subject to change without notice.

Wiring Diagrams 1

