

SPECIFICATION SHEET : PET-230-12-060

This Is An Original Product From Fulham Electronic Co., Ltd

Description :PET Series, Dimmable Electronic Transformer, Auto Reset Electronic Short Circuit And Overload Protection, High Power Factor, Low Total Harmonic Distortion

This Dimmable Electronic Transformer Will Operate The Following Lamps.



QT9/12-ax



QR-CBC35/51

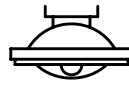

QR-LP111 12V Halogen Lamp

ELECTRICAL DATA

INPUT VOLT: 220~240V, 50/60Hz				
LAMP WATTS/TYPE	10W	20W	35W	50W
LAMPS OPERATED	6	3	2	1
MIN INPUT WATTS	20W			
MAX INPUT WATTS	60W			
OUTPUT VOLT	11.5			
MAX. LINE CURRENT	0.25A			
POWER FACTOR	>0.99			
THD	<12%			
DIMMABLE	YES			
EMI/RFI COMPLIANCE	EN55015			
SOUND RATING	"A"			
PROTECTION	Short Circuit/Over Load Protection (Auto-Reset) 、 Temperature Protection			
MAX. AMBIENT TEMP	40 °C (104 ° F)			
MAX. CASE TEMP	75 °C (167 ° F)			
APPROVALS/CLASS	TUV, RoHS			

MECHANICAL DATA

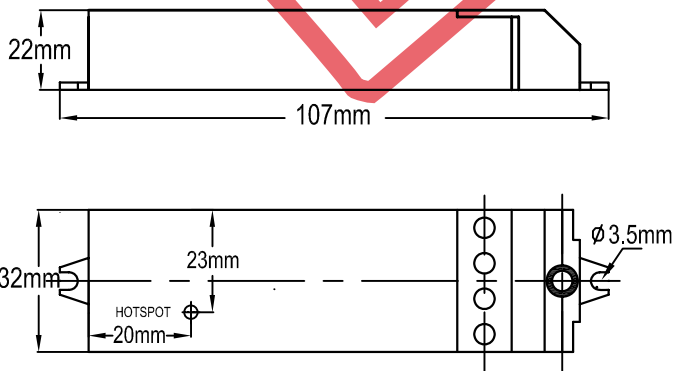

WIRING DIAGRAMS

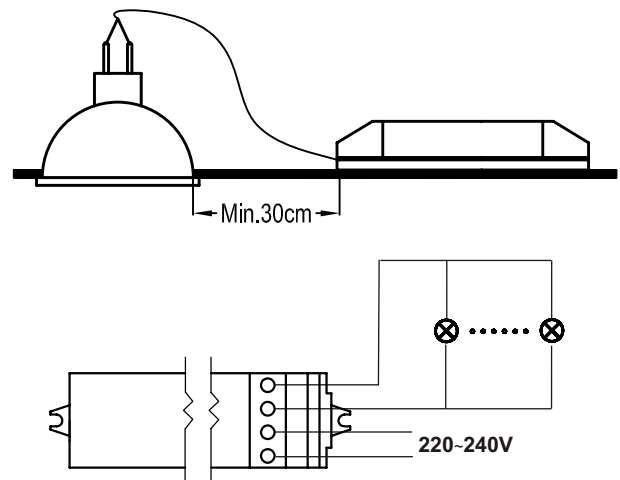

NOTE : This Transformer Must Not Be Grounded-Protection Class II

Fulham Electronic Co., Ltd extends limited warranty only to the original purchaser or to the first user for the period of 2 years from the date of manufacture when properly installed and under normal conditions of use.

DUE TO A PROGRAM OF CONTINUOUS IMPROVEMENT, FULHAM ELECTRONIC Co.,LTD RESERVES THE RIGHT TO MAKE ANY VARIATION IN DESIGN OR CONSTRUCTION TO THE EQUIPMENT DESCRIBED.

Manufacturer Address : No.9 Xing Chang Road, Chan Ping Science Park, Bei Jing 102200, China Tel.:86-10-60735858, Fax.: 86-10-60733765.

Corporate Address : Unit 2617, Miramar Tower, 132 Nathan Road,T. S. T. , Kowloon, Hong Kong Website:www.fulham.com