

SPECIFICATION SHEET : NPY-120-221-LT5

This Is An Original Product From Fulham Co., Inc

**Description : PONY Series, High Frequency Electronic, Rapid Start Ballast,
* Meets Energy Star 4.0 Criteria For Applications Listed.**

This Ballast Will Operate Following Lamps.

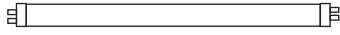

F21T5

ELECTRICAL DATA

INPUT VOLT: 120V ± 10% , 50/60Hz					
LAMP WATTS/TYPE	F21T5	F21T5	-	-	-
LAMPS OPERATED	1	2			
INPUT WATTS	27.62	49.65			
LINE CURRENT:	0.462	0.761			
POWER FACTOR	0.509	0.543			
BALLAST FACTOR	1.135	1.004			
EFFICACY FACTOR	4.112	3.022			
THD	160.90	128.30			
CURRENT CREST FACTOR	< 1.7				
EMI/RFI COMPLIANCE	FCC PART 18-B (Consumer)				
SOUND RATING	" A "				
BALLAST TYPE	RAPID START				
VOLTAGE TRANSIENTS	ANSI 62.41				
INPUT/PROTECTION	FUSE				
OUTPUT/PROTECTION	EOL				
MIN. OPERATING TEMP	0 °C (32 °F)				
MAX. CASE TEMP	75 °C (167 °F)				
ENERGY STAR 4.0	-				
APPROVALS/CLASS	UL LISTED, CLASS " P ", 1 OUTDOOR				

MECHANICAL DATA

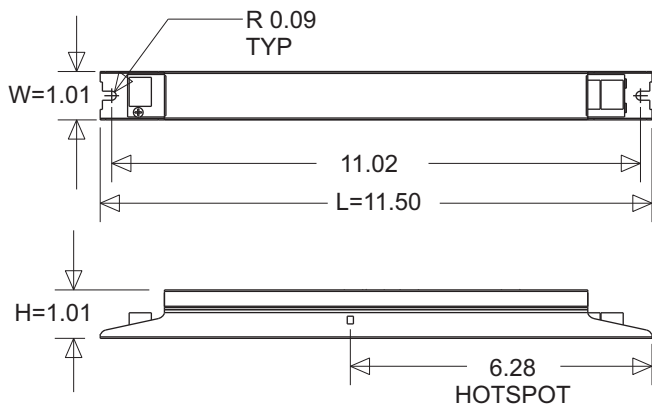

Where : L = Length, W = Width, H = Height

WIRING DIAGRAMS

WIRE	BLACK	WHITE	RED	BLUE	YELLOW	BROWN
LENGTH - INCHES	—	—	—		—	

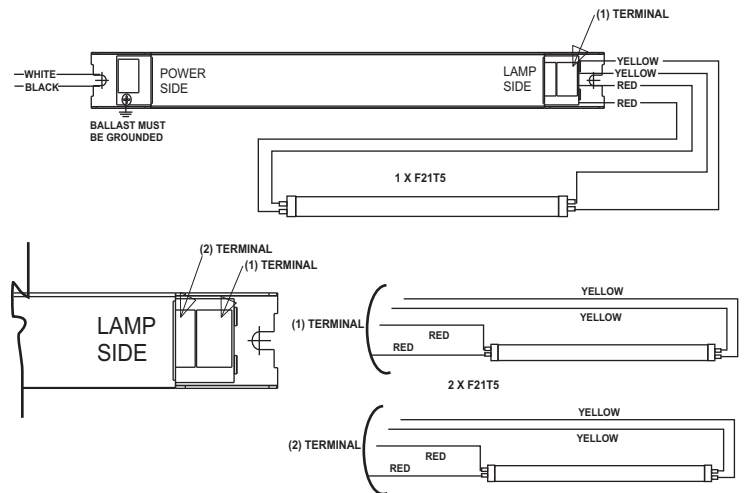

NOTE : This Ballast Case Must Be Grounded

Fulham extends a limited warranty only to the original purchaser or to the first user for a period of 2 years from the date of manufacture when properly installed and operated under normal conditions of use. For complete terms and conditions, please reference the Fulham product catalog (www.fulham.com)
Due to a program of continuous improvement, Fulham reserves the right to make modifications or variations in design or construction to the equipment described.