

SPECIFICATION SHEET : NPY-120-214-LT5

This Is An Original Product From Fulham Co., Inc

**Description : PONY Series, High Frequency Electronic, Rapid Start Ballast,
* Meets Energy Star 4.0 Criteria For Applications Listed.**

This Ballast Will Operate Following Lamps.



F14T5

ELECTRICAL DATA

INPUT VOLT: 120V ± 10%, 50/60Hz									
LAMP WATTS/TYPE	F14T5	* F14T5	-	-	-	-	-	-	-
LAMPS OPERATED	1	2							
INPUT WATTS	19.41	33.80							
LINE CURRENT:	0.333	0.490							
POWER FACTOR	0.501	0.533							
BALLAST FACTOR	1.037	0.952							
EFFICACY FACTOR	5.344	2.606							
THD	176.30	134.30							
CURRENT CREST FACTOR	< 1.7								
EMI/RFI COMPLIANCE	FCC PART 18-B (Consumer)								
SOUND RATING	" A "								
BALLAST TYPE	RAPID START								
VOLTAGE TRANSIENTS	ANSI 62.41								
INPUT/PROTECTION	FUZE								
OUTPUT/PROTECTION	EOL								
MIN. OPERATING TEMP	-10 °C (14 °F)								
MAX. CASE TEMP	75 °C (167 °F)								
ENERGY STAR 4.0	-								
APPROVALS/CLASS	UL /cUL LISTED, CLASS " P ", 1 OUTDOOR								

MECHANICAL DATA

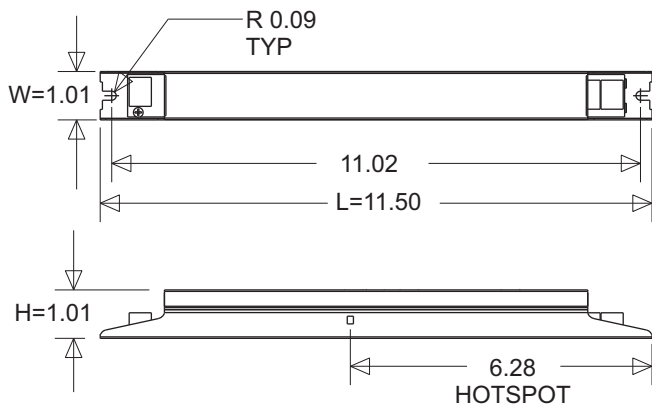

WIRING DIAGRAMS

WIRE	BLACK	WHITE	RED	BLUE	YELLOW	BROWN
LENGTH - INCHES						

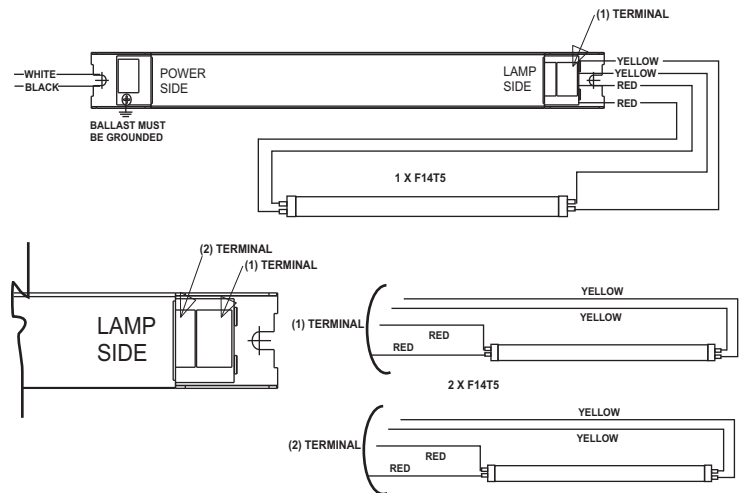

Fulham extends a limited warranty only to the original purchaser or to the first user for a period of 2 years from the date of manufacture when properly installed and operated under normal conditions of use. For complete terms and conditions, please reference the Fulham product catalog (www.fulham.com)
Due to a program of continuous improvement, Fulham reserves the right to make modifications or variations in design or construction to the equipment described.