

SPECIFICATION SHEET : LH6-120-L

This Is An Original Product From Fulham Co., Inc

Description : LongHorse Series Versatile, Solid State Electronic Ballast. Small Case Size, High Power Factor, Light Weight, Available In 120/277V 50/60 Hz.

This Ballast Will Operate Following Lamps.

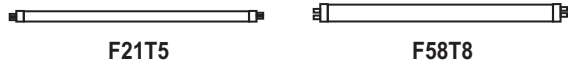

ELECTRICAL DATA

INPUT VOLT: 120V ± 10%, 50/60Hz					
LAMP WATTS/TYPE	LAMPS OPERATED	INPUT WATTS	LINE CURRENT	BALLAST FACTOR	EFFICACY FACTOR
F21T5	3	71	0.63	1.0	1.4
F21T5	4	85	0.82	0.9	1.1
F58T8	1	50	0.46	0.9	1.8
POWER FACTOR > 0.9					
THD < 34.6 %					
EMI/RFI COMPLIANCE FCC PART 18-A					
SOUND RATING " A "					
BALLAST TYPE INSTANT START					
VOLTAGE TRANSIENTS ANSI C82.11 - 1993					
INPUT/PROTECTION FUSE					
REMOTE MOUNTING 20ft Max.					
MIN. OPERATING TEMP - 30 °C (- 20 °F)					
MAX. CASE TEMP 70 °C (158 °F)					
APPROVALS/CLASS UL /cUL LISTED, CLASS " P ", 1 OR 2 OUTDOOR					

MECHANICAL DATA

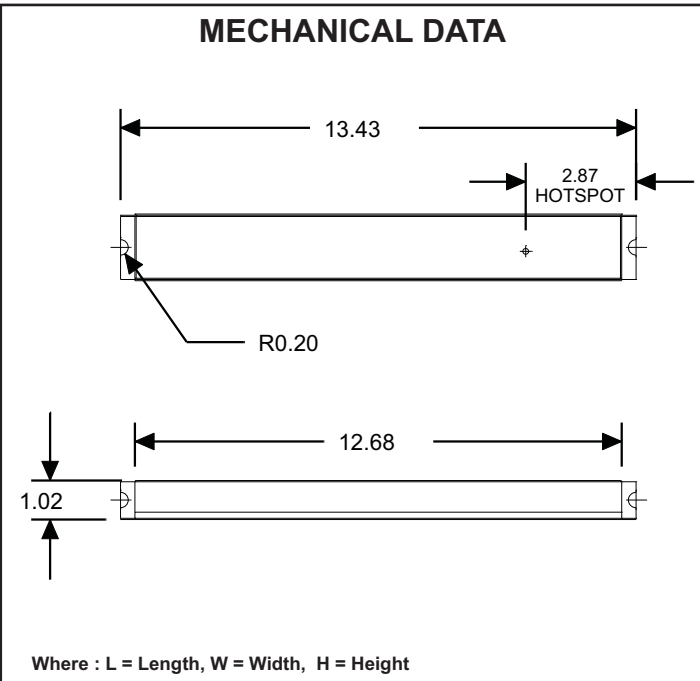

WIRING DIAGRAMS

WIRE	BLACK	WHITE	RED	BLUE	YELLOW	BROWN
LENGTH - INCHES	18 ± 1"	18 ± 1"	36 ± 1"	-	36 ± 1"	-

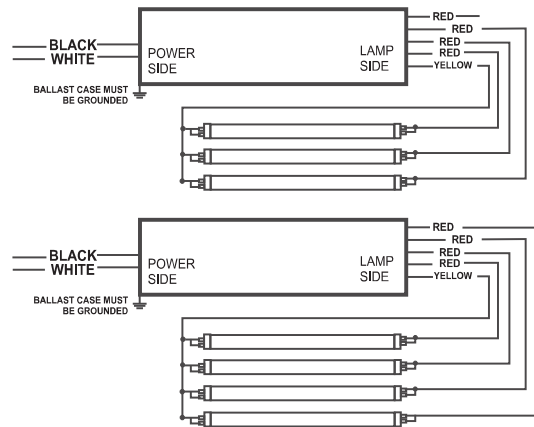

NOTE : This Ballast Must Be Grounded

Fulham Co., Inc extends limited warranty only to the original purchaser or to the first user for the period of 5 years from the date of manufacture as indicated by the date code stamped on each product and when properly installed and under normal conditions of use. For additional warranty guide line, please refer to our Complete Product Catalog OR call Customer Service at 1-323-599-5000.

DUE TO A PROGRAM OF CONTINUOUS IMPROVEMENT, FULHAM Co., INC RESERVES THE RIGHT TO MAKE ANY VARIATION IN DESIGN OR CONSTRUCTION TO THE EQUIPMENT DESCRIBED.

Address : 12705 South Van Ness Ave., Hawthorne, CA 90250 Tel.: 1-323-599-5000, Fax.: 1-323-754-9060. Website: www.fulham.com 2010-55SP rev E