

# FHEM12W Series: INSTALLATION INSTRUCTIONS FOR EMERGENCY LIGHTING FIXTURE

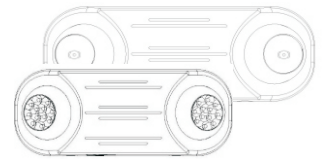

## IMPORTANT SAFEGUARDS:

When using electrical equipment, basic safety precautions should always be followed. Including the following

- 1) READ AND FOLLOW ALL SAFETY INSTRUCTIONS
- 2) Rated for temperature range of 10°C-40°C (50°F-104°F) and suitable for use in an application that is designated as a damp location area as defined by NEC Article 100, Location, Damp.
- 3) Used indoors.
- 4) Equipment should be mounted at heights to prevent tampering by unauthorized personnel.
- 5) Do not mount near gas or electric heaters.
- 6) The use of accessory equipment is not recommended by the manufacturer and may cause an unsafe condition.
- 7) Do not use this equipment for anything other than its intended use.
- 8) Servicing of this equipment should be performed by qualified personnel.
- 9) Disconnect AC power before servicing.

## IMPORTANT:

The battery in this unit may not be fully charged. After electricity is connected to unit, let battery charge up for at least 24 hours. Then the normal operation of this unit should take effect. To check press the "TEST" button and the lights on the unit should turn ON.

SAVE THESE INSTRUCTIONS

## Installation Instructions:

### J-Box Mounting

- 1) Open the Base plate and lead out a wire after getting through the hole on the Base plate. Fix the Base plate on J-Box with screws.
- 2) Then connect to AC power (Fig.A).
- 3) Connect to the battery with connectors (Fig.B).
- 4) Install the housing to Base plate, turn on the AC power and press the "TEST" button check light (Fig.C).
- 5) Secure face plate to housing. Remove the proper arrow as required.

### Conduit

- 1) Secure Base Plate to wall surface. Route wires through hole in conduit flange and make conduit connection. Use flexible conduit only.
- 2) Connect battery only after continuous AC power is being supplied to the unit (Fig. B).
- 3) Align snaps and push housing directly onto the Base Plate (Fig. C). Apply continuous AC power and press "TEST" button to check light.

**WARNING:**  
Unused wires must be capped using enclosed wire nuts.

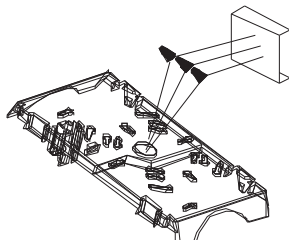

Fig. 1

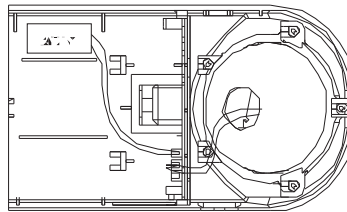

Fig. 2

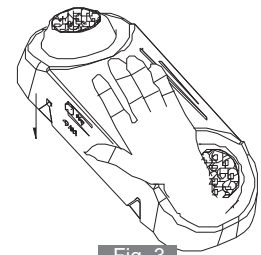
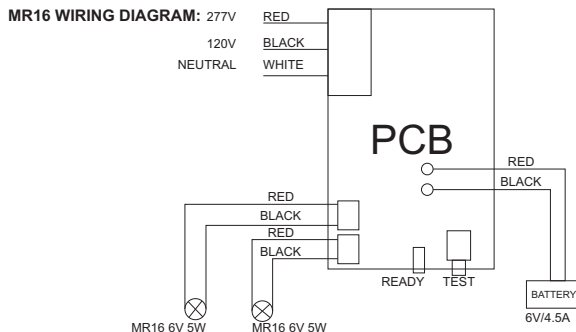
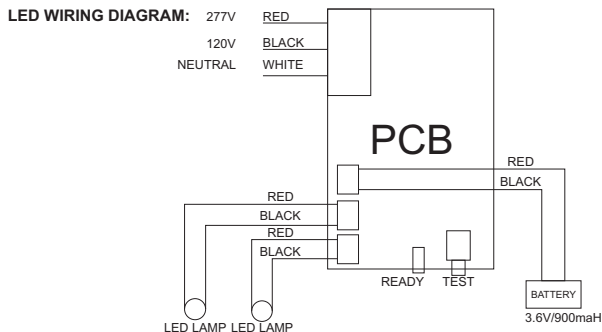

Fig. 3

## OPERATION:

1. During an electrical power failure, the lamps on the unit will automatically come ON for a minimum of 90 minutes.
2. To test this unit, let it charge correctly with AC power supply for a minimum of 24 hours after its first installation and then depress the "TEST" switch, the emergency lamps will illuminate. When the switch is released, the lamps will turn OFF.

## WIRING DIAGRAM:



**NOTE:** UNUSED LEAD TO BE PROPERLY INSULATED WITH WIRE NUT OR OTHER APPROVED METHOD

Fulham extends a limited warranty only to the original purchaser or to the first user for a period of **5 years** from the date of manufacture when properly installed and operated under normal conditions of use. For complete terms and conditions, please reference the Fulham product catalog ([www.fulham.com](http://www.fulham.com)) **Due to a program of continuous improvement, Fulham reserves the right to make modifications or variations in design or construction to the equipment described.**