

Mechanical Data:

4.25" x 4.75" CORE-2 COIL UNIT

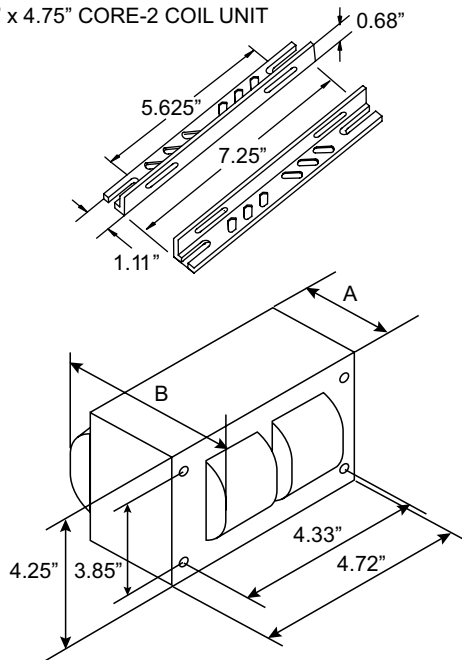

DIMENSION A	1.77 IN
DIMENSION B	3.50 IN
TOTAL WEIGHT	10.58 LBS
LEAD LENGTHS	12 IN
HARDWARE KIT: HH-MH-HDW2 CLAMP: HH-MH-IGCLMP	
2 2" Thru-Bolts	4 Flat Washers
2 Lock Washers	2 Nuts

Electrical Data:

INPUT VOLTS	120	208	240	277
MINIMUM STARTING TEMPERATURE	-20°F or -30°C			
POWER FACTOR	90%			
ANSI CODE	250 WATT LAMP, S-50			
CIRCUIT TYPE	CWA			
WATTS INPUT	289			
MAX INPUT CURRENT	2.50	1.50	1.30	1.10
NOM. OPEN CIRCUIT VOLTAGE	187			
RECOMMENDED FUSE (Amps)	7	4	4	3
REGULATION				
LINE VOLTS	±10%			
LAMPS WATTS	±10%			
INPUT WATTS AT LAMP DROPOUT	66	100	106	118
LINE CURRENT (AMPS)				
OPERATING	2.50	1.50	1.30	1.10
OPEN CIRCUIT	1.65	0.95	0.85	0.75
STARTING	1.52	0.88	0.76	0.66
UL TEMPERATURE RATINGS				
INSULATION CLASS	H(180)			
COIL TEMPERATURE CODE	1029			
CAPACITOR REQUIREMENT				
MFD	35uF			
MIN VOLT	240			
IGNITOR				
PART NUMBER	HH-HPS-IG200-400			
MAX DIST TO LAMP	2 FT			
60Hz TEST PROCEDURES				
HIGH POTENTIAL TEST (VOLTS)	1 MIN: 2000, 2 SEC: 2500			
OPEN CIRCUIT VOLTAGE TEST (VOLTS)	170-205			
SHORT CIRCUIT CURRENT TEST (AMPS)	3.70-4.50			
SECONDARY CURRENT				
INPUT CURRENT	1.34	0.73	0.68	0.58

Ignitor:

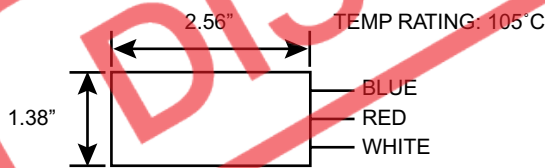

Capacitor:

Wet Capacitor: HHHPS-WCAP-250

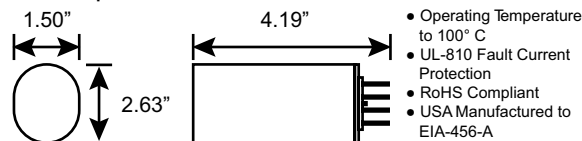

Dry Capacitor: HHHPS-DCAP-250

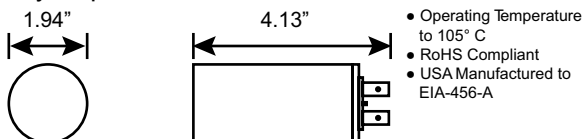

Wiring Diagram:

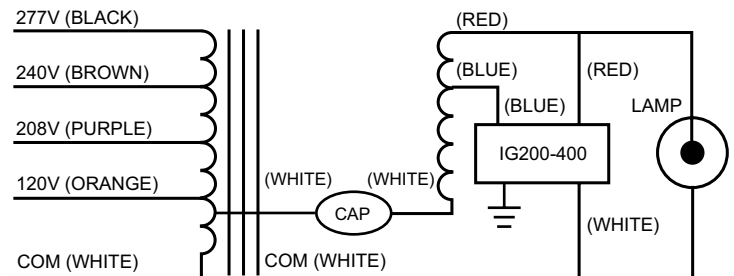

Options:

Basic Ballast Kit includes Ballast, Ignitor and Mounting Hardware only.
 For capacitor option, add Base Model No. and one Capacitor code:
D = Dry Kit: Ballast + Ignitor + Dry Capacitor + Mounting Hardware
W = Wet Kit: Ballast + Ignitor + Wet Capacitor + Mounting Hardware

HID Ballast and Lamp Kits also available; please see website www.fulham.com.