

Mechanical Data:

4.25" x 4.75" CORE-2 COIL UNIT

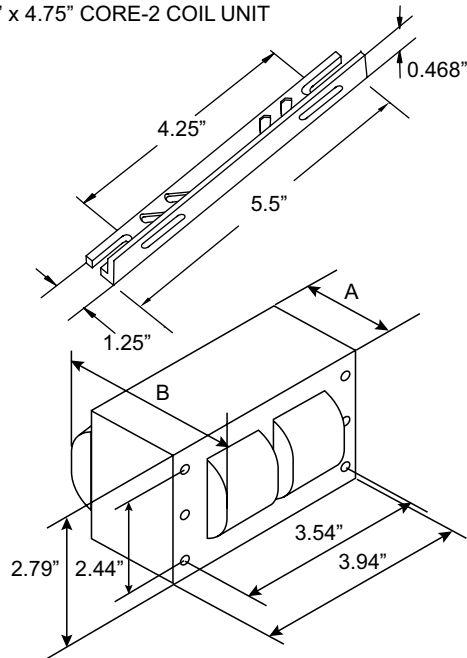

DIMENSION A	2.00 IN
DIMENSION B	3.35 IN
TOTAL WEIGHT	6.61 LBS
LEAD LENGTHS	12 IN

HARDWARE KIT: HH-MH-HDW3 CLAMP: HH-MH-IGCLMP
 2 3" Thru-Bolts 4 Flat Washers
 2 Lock Washers 2 Nuts

Electrical Data:

INPUT VOLTS	120	208	240	277
MINIMUM STARTING TEMPERATURE	-20°F or -30°C			
POWER FACTOR	90%			
ANSI CODE	100 WATT LAMP, S-54			
CIRCUIT TYPE	HX-HPF			
WATTS INPUT	120			
MAX INPUT CURRENT	1.14	0.66	0.57	0.49
NOM. OPEN CIRCUIT VOLTAGE	120			
RECOMMENDED FUSE (Amps)	3	2	2	2
REGULATION				
LINE VOLTS	±10%			
LAMPS WATTS	±10%			
INPUT WATTS AT LAMP DROPOUT	84	132	181	230
LINE CURRENT (AMPS)				
OPERATING	1.14	0.66	0.57	0.49
OPEN CIRCUIT	0.275	0.160	0.138	0.119
STARTING	0.78	0.46	0.38	0.34
UL TEMPERATURE RATINGS				
INSULATION CLASS	H(180)			
COIL TEMPERATURE CODE	1029			
CAPACITOR REQUIREMENT				
MFD	10uF			
MIN VOLT	280			
IGNITOR				
PART NUMBER	HH-HPS-IG70-150			
MAX DIST TO LAMP	2 FT			
60Hz TEST PROCEDURES				
HIGH POTENTIAL TEST (VOLTS)	1 MIN: 2000, 2 SEC: 2500			
OPEN CIRCUIT VOLTAGE TEST (VOLTS)	115-125			
SHORT CIRCUIT CURRENT TEST (AMPS)	2.60-3.30			
SECONDARY CURRENT				
INPUT CURRENT	2.99	1.73	1.50	1.30

Ignitor:

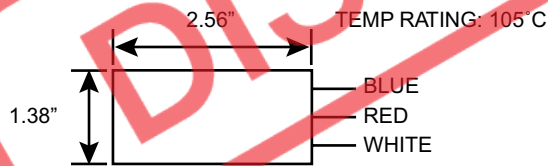

Capacitor:

Wet Capacitor: HHHPS-WCAP-100



Dry Capacitor: HHHPS-DCAP-100

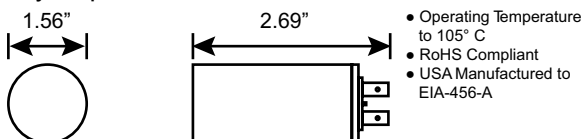

Wiring Diagram:

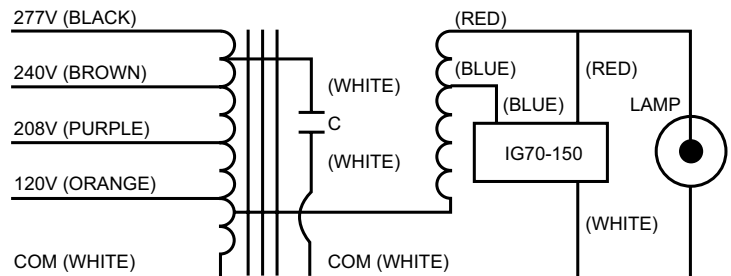

Options:

Basic Ballast Kit includes Ballast, Ignitor and Mounting Hardware only. For capacitor option, add Base Model No. and one Capacitor code:
D = Dry Kit: Ballast + Ignitor + Dry Capacitor + Mounting Hardware
W = Wet Kit: Ballast + Ignitor + Wet Capacitor + Mounting Hardware

HID Ballast and Lamp Kits also available; please see website www.fulham.com.