



# FHSAC1-230-70SE



## Programmable Normal and Emergency LED Driver

- Input Voltage: 200-240V~
- Output Voltage Range: 11-55V=
- Output Current: 350-2400mA
- Built-In
- Output Power: 70W for LED load
- Emergency Output Power: 3W-7W
- Self-Diagnostics
- 0-10V Dimmable: 100%-1%, 0% or Pulse DIM

### General Specifications

Input Voltage / Frequency	200-240V~, 50/60Hz
Input Current	0.43A @200VAC
Input Power	85W (Max.)
Input PF	>0.9@Full Load, >0.9@Half Load
THD	<10%@Full Load, 230Vin; <10%@Half Load, 230Vin
Efficiency	>90%@ 29.2Vout/1920mA-2400mA >91.5%@ 55.0Vout/1020mA-1270mA
Output Class	SELV
Output Voltage Range	11-55V=
Output Current	350mA-2400mA, (R-set 350-2400)
Output Power	70W for LED load
Battery Type	LiFePo4
Battery Voltage	3.2V for each battery
Battery Capacities	1500mAh
Battery Charge Current	<250mA
Battery Recharge Time	<12 Hours
Battery Discharge Time	>60 minutes
Dimming Type	0-10V or Pulse DIM
EM Output Type	Programmable Constant Power Output
Operating Ambient Temperature Range	0°C to 50°C (32°F to 122°F) ta(3~4W Emergency) 10°C to 50°C (50°F to 122°F) ta(5~7W Emergency)
Overall Size	16.7"L x 1.18"W x 1.0"H(424mm L x 30mm W x 25.4mm H)
Weight	607g / 1.33lb.
Potting Type / Degree of Fill	Partial Potting
RFI/EMI	EN55015
Operating Humidity	20-95% RH Non-condensing
Protections	Input Voltage Surge 2.0kV / 2.0kV Output Short Circuit Protection Overload Protection Input Under Voltage Protection Over Temperature Protection
Hot Swappable	NO
Sound Rating	A
Service Life	50,000 hours
Warranty	5 years
Safety / Compliance	RoHS / REACH Compliant CE, EN61347-1, EN61347-2-13, EN62384, EN50172, EN61547 EN62493, EN62034, EN60730, EN61347-2-7, EN61000-3-2, EN61000-3-3, EN61000-4-2, EN61000-4-3 EN61000-4-4, EN61000-4-5, EN61000-4-6, EN61000-4-8 EN61000-4-11, EN61000-4-29
EOF1	0.0645



# FHSAC1-230-70SE

Typical Characteristics Graphs: Input



Figure 1

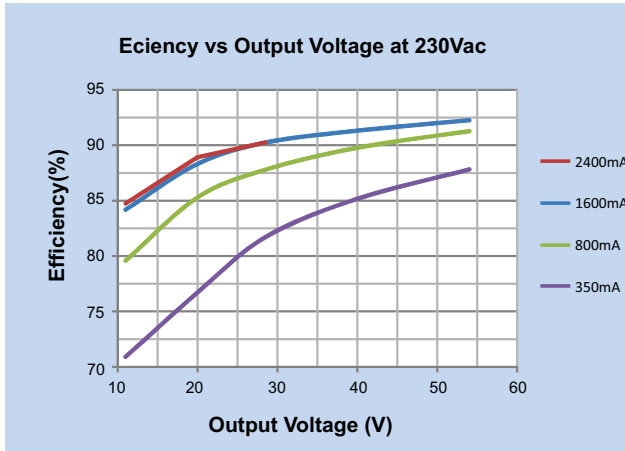

Figure 2

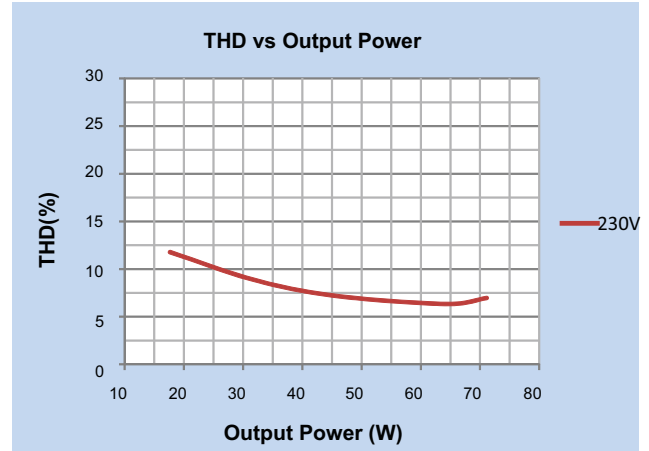
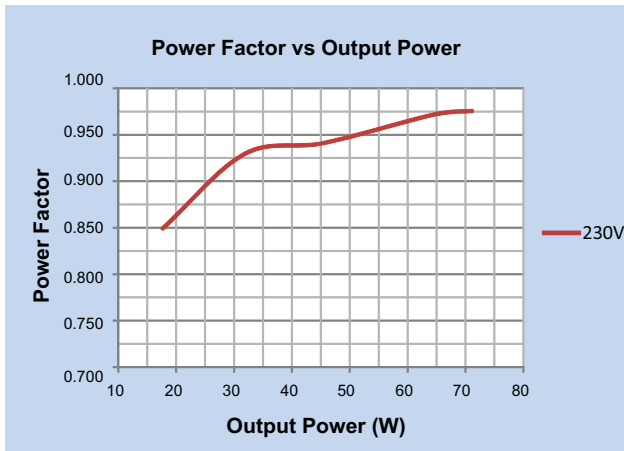

Figure 3





# FHSAC1-230-70SE



## Typical Characteristics Graphs: Dimming and Thermal

Figure 4

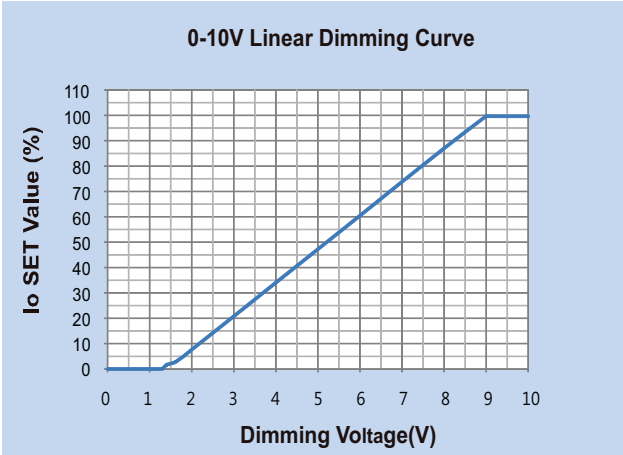

Figure 5

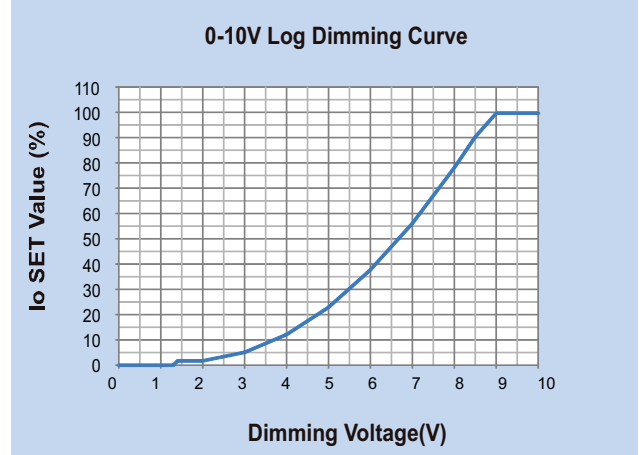

Figure 6

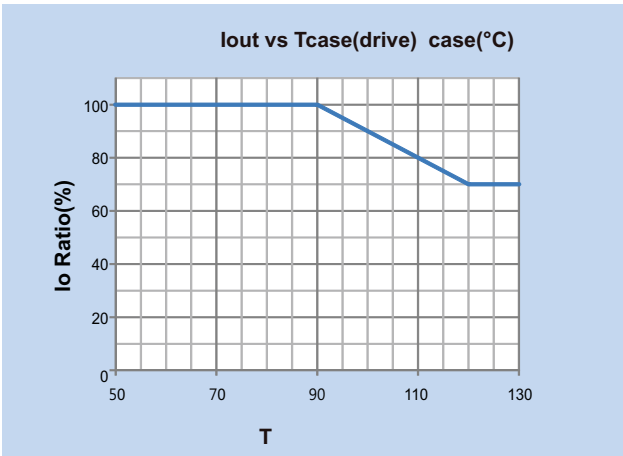
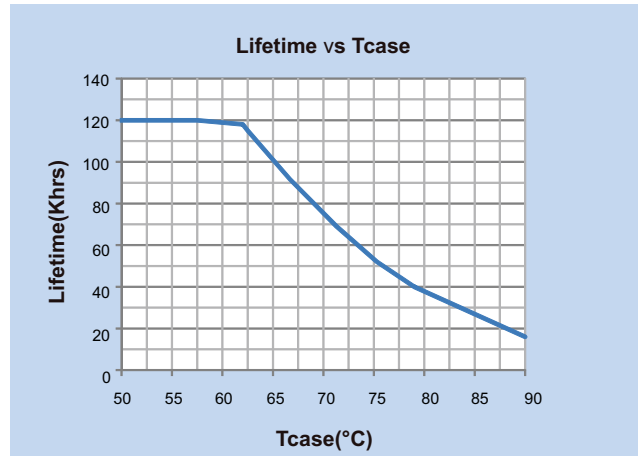

Figure 7



Failure Rate Info base  
90% survivals at end of life @ ≤Tc lifetime rating



# FHSAC1-230-70SE



## Typical Characteristics Graphs: Output

Figure 8

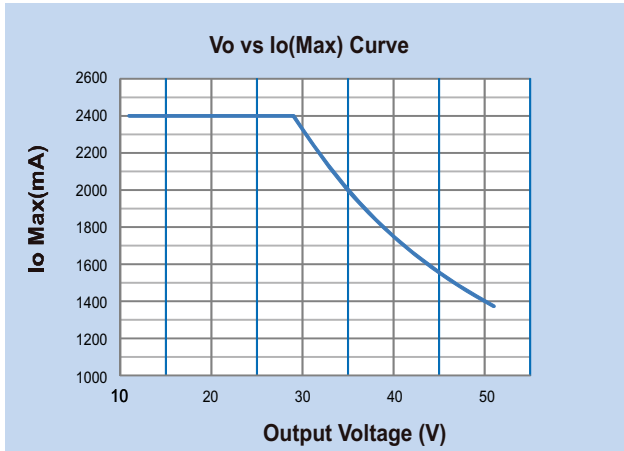

Figure 9

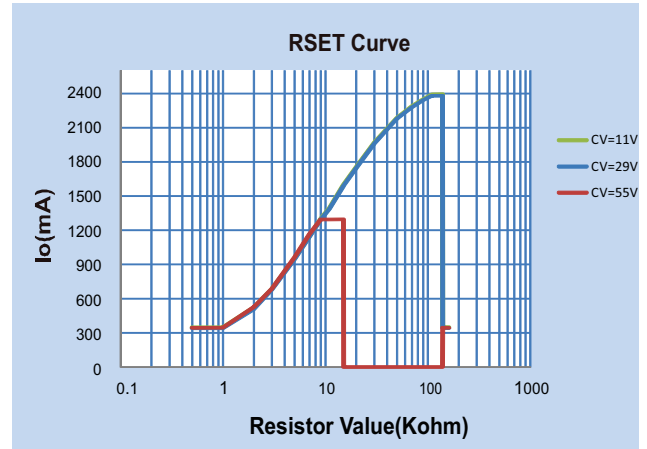
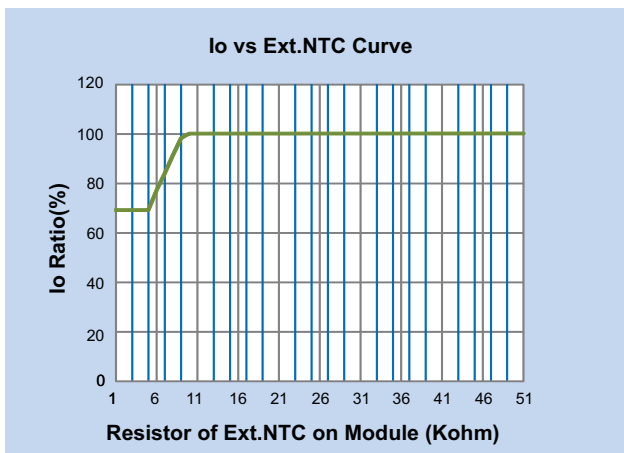

Figure 10





# FHSAC1-230-70SE



## Mechanical Drawings

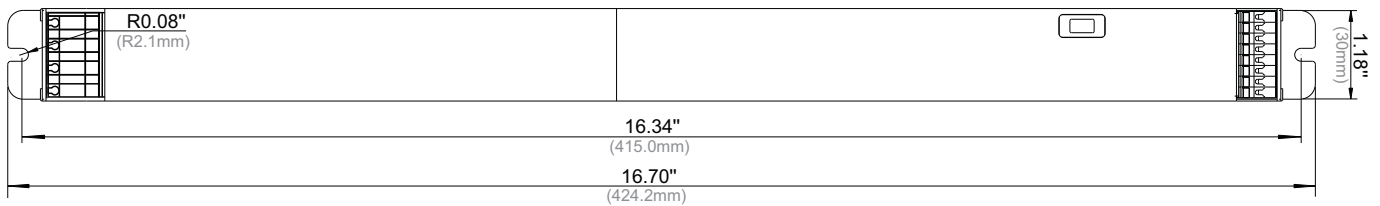

TOP VIEW

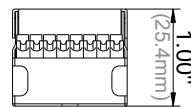

SIDE VIEW

Tolerance=±0.02"

Overall Dimensions	
Length	16.70" [424.2mm]
Width	1.18" [30mm]
Height	1.00" [25.4mm]

## Wire Diagram



### NOTES :

- 1) This driver must be installed by a licensed electrician.
- 2) This driver must be grounded.
- 3) Once the unit has entered into a self-diagnostic cycle it will not exit until it has fully concluded testing regardless of power cycling to the input. In order to exit you must manually hold the test button for 10 seconds or allow the testing to conclude.

**CAUTION:** Replace battery only with FHSBATL3-1.5HSP.

**CAUTION:** The control gear is not intended for use in luminaires for high-risk task area lighting.

**ATTENTION:** Remplacer la batterie uniquement par une FHSBATL3-1.5HSP.



# FHSAC1-230-70SE



## Accessories

### Test Switch (Included)

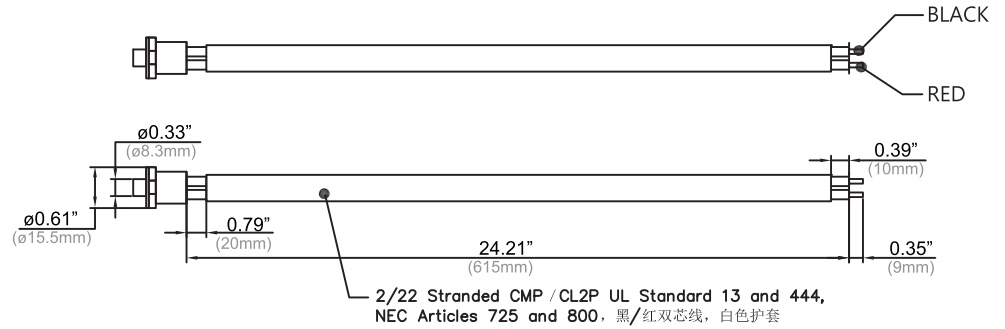

### Bi-Color Wet Location Test Switch: FHS-TSTWL-BC (Optional)

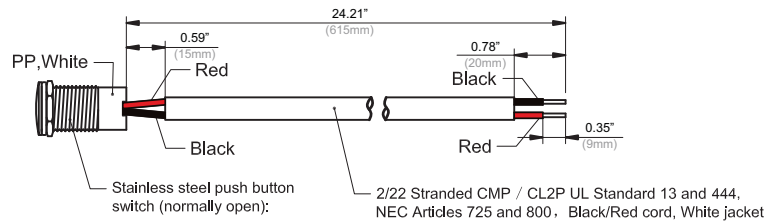

#### Overall Switch Dimension

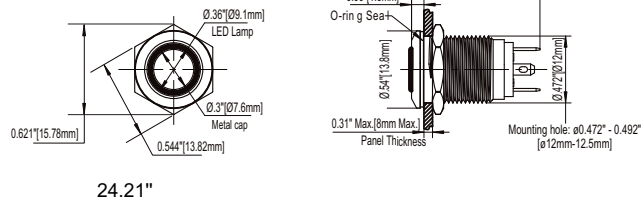

### Wall Plate: FHSWLPWH



Wall plate and screw color:  
white with black lettering

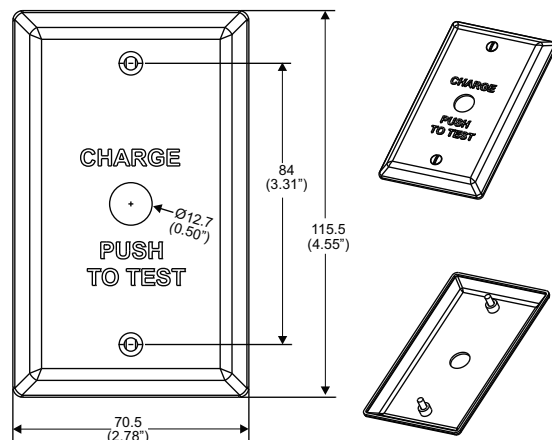

1. "Charge push to Test" plate
2. (2) 6-32 x 1/2" LG mounting screws



# FHSAC1-230-70SE



---

## Guidelines

### Grounding

- Driver must be grounded by means of the Driver case.

---

### Over temperature protection

- The Fulham Hotspot Plus LED drivers are protected against thermal overload. If the temperature limit is exceeded, the output current is reduced.

---

### LED load

- Fulham Hotspot Plus LED drivers are designed to drive passive LEDs, -COB's and -LED assemblies Proper function is not guaranteed when (LED) loads with active components are used.

---

### Programming

For detailed programming instructions please see our Programming Instructions and Design Guide found on our website:  
<https://www.fulham.com/PDFs/SpecSheets/Fulham-Design-Guide-Programmable-Drivers.pdf>

---

### Mounting / Cooling

- Above an output power of 20W, the driver needs to be mounted on a heat conductive surface of at least 200cm<sup>2</sup>. Always test if the surface is sufficient enough before installing the driver.

---

### Short-circuit protection

- In case of a short circuit the LED driver switches to protection mode. After the removal of the short-circuit the LED driver will recover automatically.

---

### No-load Operation

- In no-load operation the output voltage will not exceed the specified open circuit output voltage.

---

### Hot Swapping

- This driver does not support hot swapping of the LEDs

---

### Remote Mounting

Up to 15ft with 18AWG. Contact Fulham for higher remote distance.

---

### Battery Maintenance

- In order to maintain proper operation and warranty coverage, the battery must be recharged once per year prior to installation.

---

### Warranty

- Reference Fulham's limited Warranty: <https://cdn.fulham.com/PDFs/Limited-Warranty.pdf>



# FHSAC1-230-70SE



## Part Number Matrix

**FHS**

**AC**

**1**

**230**

**70**

**S**

**E**

FHS

FHS = FireHorse HotSpot Driver

AC LED Driver

AC=AC LED Driver

LED Driver Number

1 = Programmable Output

Input Voltage

230 = 230V

Power

70 = 70W

Case Type

S = Stick

Standard

E = IEC

## Product Image: LED Driver

FHSAC1-230-70SE



## Packaging

Master Carton

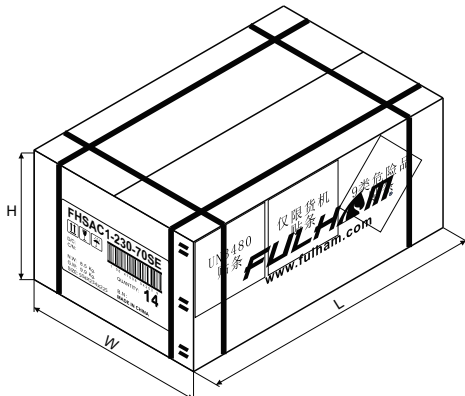

OUTER DIMENSION		
L	W	H
19.84(504mm)	9.21(234mm)	8.86(225mm)
Net Weight	Gross Weight	QUANTITY
18.74 lbs. (8.5kg)	21.83lbs. (9.9 kg)	14pcs.