



# FHS-TSTWL-BC-S

RoHS  
COMPLIANT

## Wet Location Test Switch

- Stainless Steel

This Test Switch Will Operate The Following Fulham Emergency LED Driver : FHS2-UNV-36L, FHS2-UNV-56S, FHSAC1-UNV-40C, FHSAC1-UNV-40L, FHSAC1-UNV-40BLS, FHSAC1-230-45CE, FHSCP-UNV-10P-L-SD.

### General Specifications

LED Color	Red
Ambient Operating Temperature Rang	-25°C to 55°C (-13°F to 131°F)
Mechanical Life	>100.0000 Cycles
Warranty	5 Years

### Mechanical Drawings

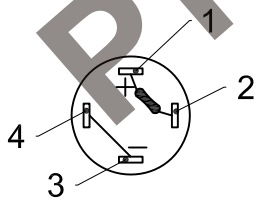
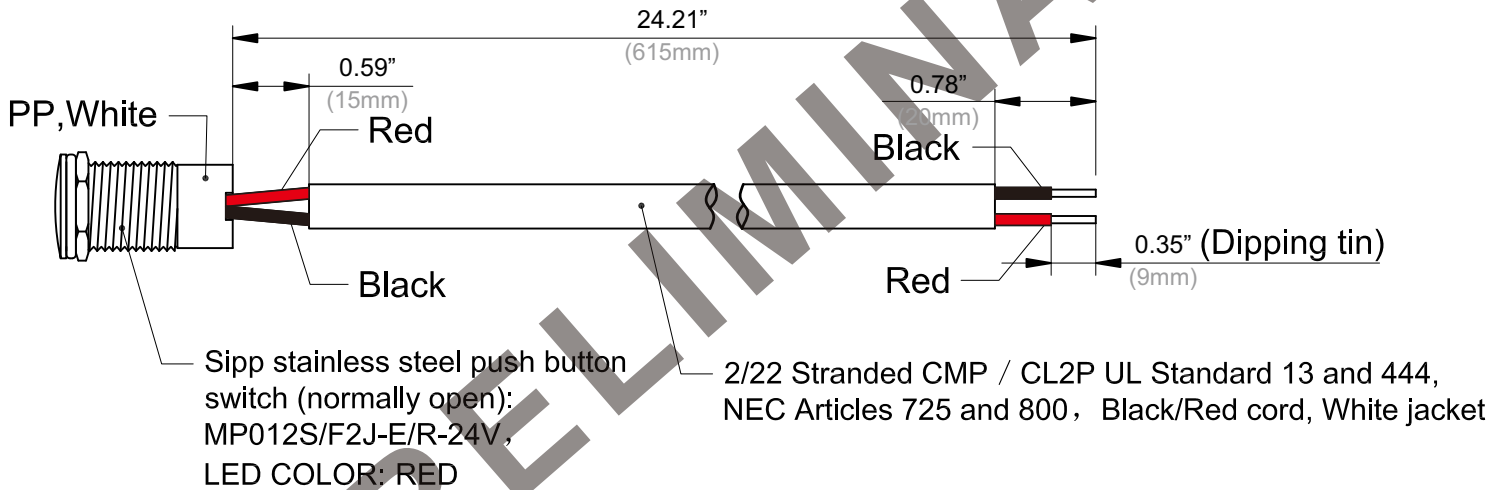

Welding Diagram  
2:1

1, 2 foot welding resistance, resistance specification: metal film 1/6w 2K OHM 1%;  
3, 4 feet short joint;  
2 feet for red line and 3 feet for black line.

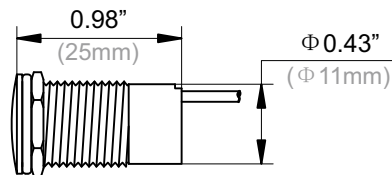



# FHS-TSTWL-BC-S

RoHS  
COMPLIANT

## Part Number Matrix

**FHS**

LED Driver  
FHS = FireHorse HotSpot

**TST**

Accessory Type  
TST = Test Switch

**WL**

Accessory  
WL = Wet Location Rated

**BC**

Accessory  
BC = Bi-Color

**S**

Reserved  
S = Stick

## Product Image: Test Switch

FHS-TSTWL-BC-S

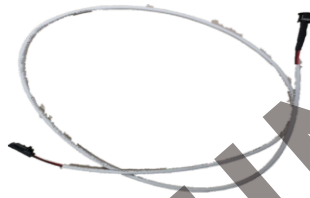

## Packaging

Master Carton

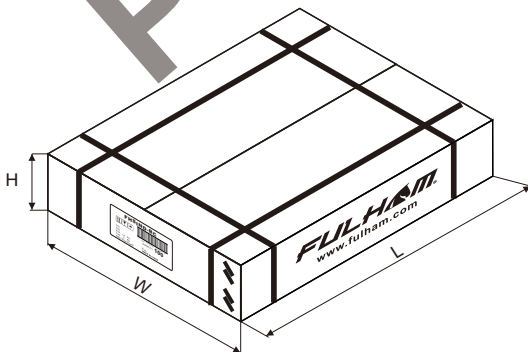

OUTER DIMENSION		
L	W	H
13.38"(340mm)	9.64"(245mm)	2.55"(65mm)
Net Weight	Gross Weight	QUANTITY
3.52 lbs. (1.6 kg)	4.4 lbs. (2 kg)	100pcs.