

INSTALLATION INSTRUCTIONS

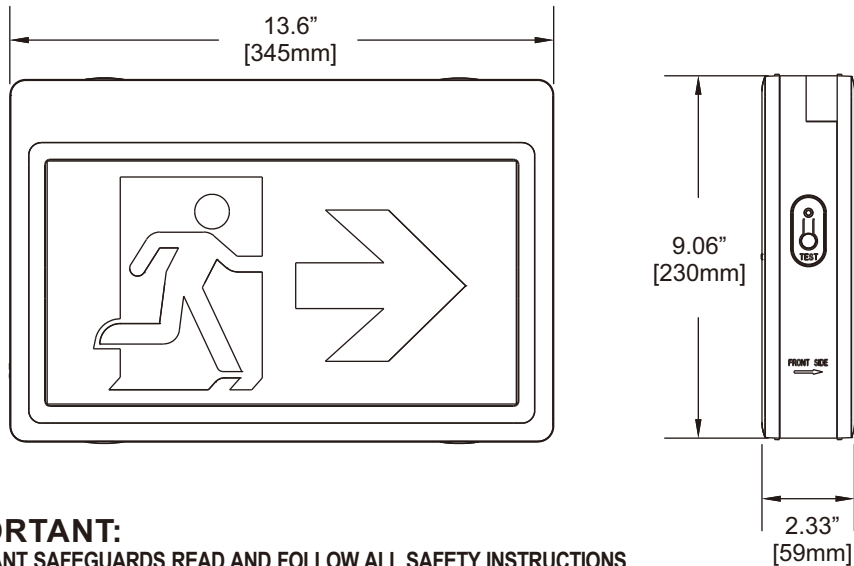

IMPORTANT:
IMPORTANT SAFEGUARDS READ AND FOLLOW ALL SAFETY INSTRUCTIONS
 When replacing the LEDs please only use LEDs specified in the exit sign.
 Using other lamp types may result in transformer damage or unsafe conditions.
 The battery in this unit requires a 24 hours charge before testing.

Model list:

Model No.	FHEU20
Rated voltage	AC120-347V~, 60Hz
Input Current	80mA
Rated wattage	4.5W
Emergency Output Rating	1W
Battery	Ni-Cd 3.6V 900mAh
Battery life	up to 4 years
Recharge Time	24 hrs
Emergency Duration	2 hrs
Power Factor	≥0.4
Operating Temp Range	0°C-40°C
Dimensions	345x59x230mm
Warranty	2 years

Mounting Instruction

Fig 1

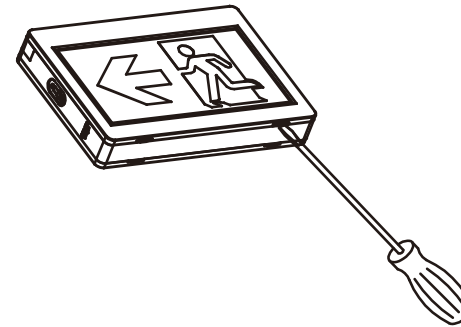

Fig 2

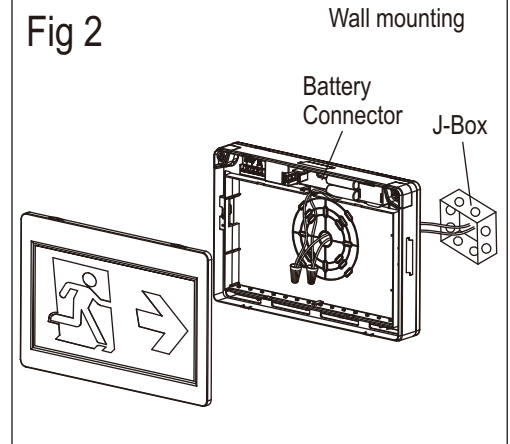

Fig 3

Side mounting

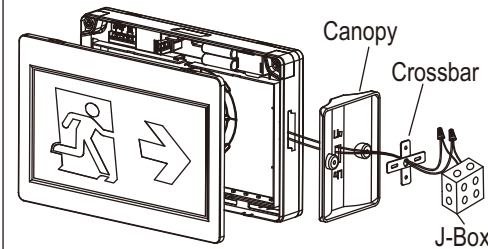

Fig 4

Ceiling mounting

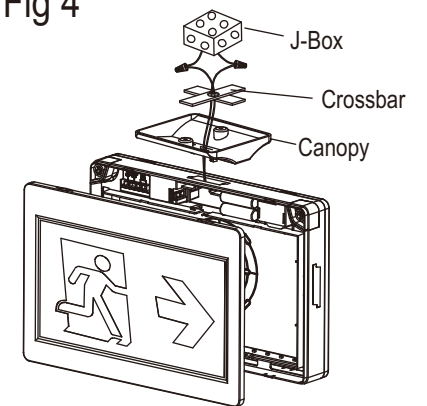
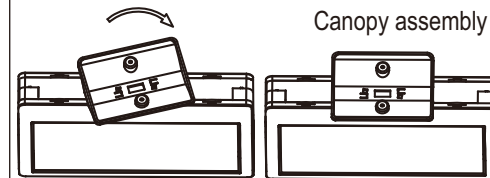
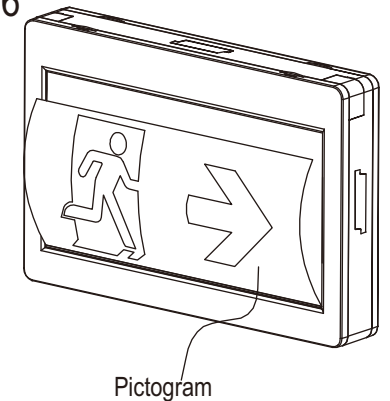

Fig 5



Insert canopy into housing at 20 degree angle and twist. The canopy is now locked firmly.
CAUTION: Trying to remove the canopy while it locked in place may cause damage.

Fig 6



THE FIXTURE IS SUITABLE FOR WALL, SIDE AND CEILING MOUNTING

1. Open front cover with flat head screwdriver. (See Fig 1)
2. Knockout appropriate mount screw hole and cable hole, mount back plate on the wall after feeding building AC Supply Cable into back plate. (See Fig 2)
3. For ceiling and side mounting purpose, remove the mounting hole cover on the top or side of the unit. (See Fig 2, 3, 4) Assemble the canopy on the unit. (See Fig 5)
4. Attach crossbar to J-Box, set the longer blade of crossbar touching the J-Box.
5. Route the proper wires through mounting hole out of housing.
6. Make electrical connections inside the J-Box as wiring diagram. (See Fig 7)
7. Push excess wire into J-Box, use screws tighten canopy to crossbar so that canopy is securely fastened and tight against the wall.
8. Attach battery connector to PC Board, reattach front cover to the unit.
9. If pictogram direction assembled is not suitable, pictogram can take out for change direction or replace pictogram. Then insert into diffuser. (See Fig 6)

Wiring Diagram(See Fig 7)

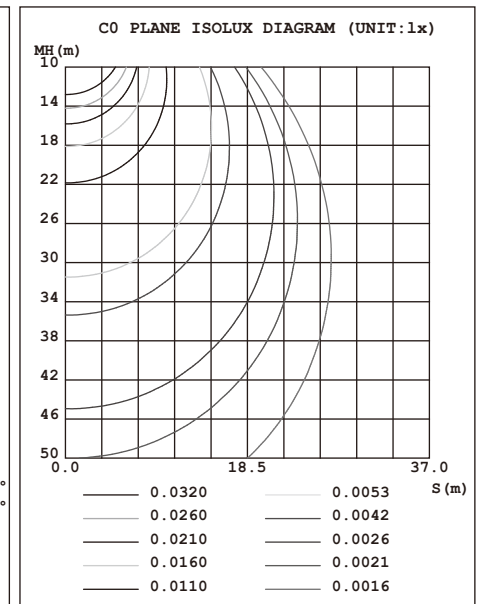
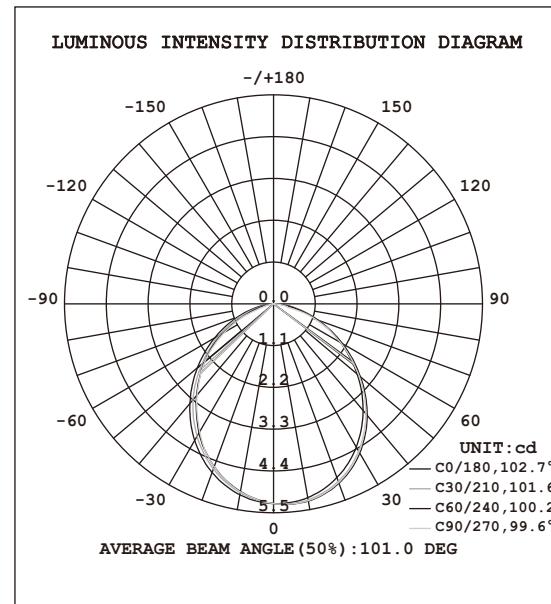
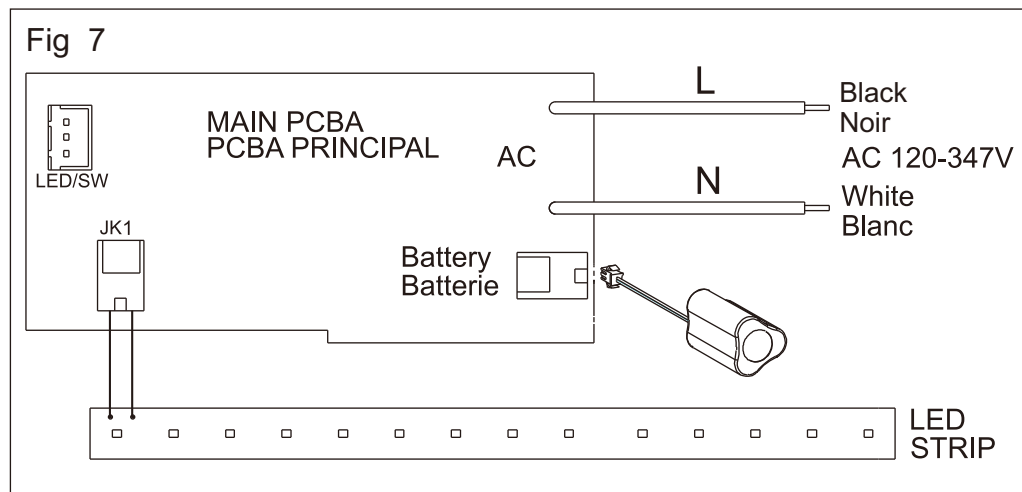

READ AND FOLLOW ALL SAFETY INSTRUCTIONS:

1. Review the diagrams thoroughly before beginning.
2. All electrical connections must be in accordance with local codes, ordinances and the National Electric Code.
3. Disconnect power at fuse or circuit breaker before installing or servicing.
4. Do not use outdoors.
5. Do not mount in hazardous locations or near gas or electric heaters.
6. Do not let power cords touch hot surfaces.
7. Equipment should be mounted in locations and at heights where it will not be subjected to tampering by unauthorized personnel.
8. The use of accessory equipment is not recommended by the manufacturer.
9. Do not use this equipment for other than its intended use.
10. All servicing should be performed by qualified personnel only.
11. Allow battery to charge for 24hrs before first use.



This marking indicates that this product should not be disposed with other household wastes throughout the EU. To prevent possible harm to the environment or human health from uncontrolled waste disposal, recycle it responsibly to promote the sustainable reuse of material resources. To return your used device, please use the return and collection systems or contact the retailer where the product was purchased. They can take this product for environmental safe recycling.