



# FHEM14



## High-Wattage Emergency Lights

- Push-to-test switch
- LED charge indicator
- Specification grade design
- Universal mount, side and top knockouts
- Maintenance free, 6V sealed lead-acid battery
- Two 6 VDC or 12 VDC, 9W or 7.2W, PAR 36 fully adjustable lamp heads
- High output remote head capability
- Constructed of impact resistant, UL 94 5VA Thermoplastic
- Dual voltage 120V/277V
- UL Listed in accordance with UL924

### General Specifications

	FHEM141250	FHEM1412100	FHEM14650
Input Voltage	120/277VAC		
Input Current (120V)	50mA		
Input Current (277V)	21mA		
Output Power	50W	100W	50W
Lamp Wattage	2 x 9W (18W)	2 x 9W (18W)	2 x 7.2W (14.4W)
Operating Frequency	60Hz		
Overall Size	12.625" L x 13.375" H		
Emergency Operation	90 minutes		
Compliance	UL 924 Listed Wet Location		
Warranty	5 years from the date of manufacture		

### Mechanical Data

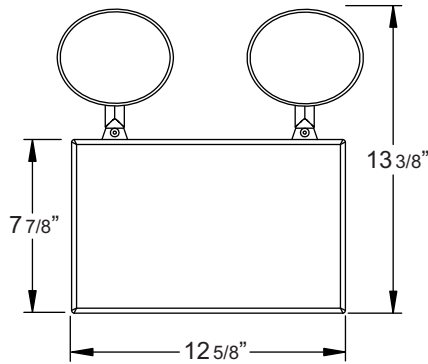

FRONT VIEW

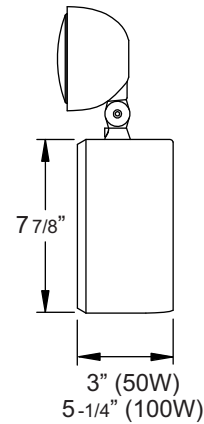

SIDE VIEW

### Part Number Matrix

FHEM14	12	50
	<u>Voltage</u>	<u>Output</u>
	6 = 6V	50 = 50W
	12 = 12V	100 = 100W

This product does not meet CEC Title 20 Code of Regulations.