

SPECIFICATION SHEET : FEP-210-600-L

This Is An Original Product From Fulham Co., Inc

Description : Sun Horse electronic ballast developed for use with UV & tanning lamp applications

This Ballast Will Operate Following Lamps.



F59T12H0(85W) / F72T12HO(100W) / F79T12HO(200W)

ELECTRICAL DATA (210V APPLICATION)

| INPUT VOLT: 210V ± 10% 50/60Hz | | | | | | | | | |
|--------------------------------|-------------------------------------|-------------------|------------------|-------------------|------------------|-------------------|--------------------|--------------------|--------------------|
| LAMP WATTS TYPE | F59T12-HO 85W | F72T12-HO 100W | F59T12-HO 85W | F72T12-HO 100W | F59T12-HO 85W | F72T12-HO 100W | F72T12M-HO 160W | F79T12M-HO 200W | F79T12M-HO 200W |
| LAMPS OPERATED | 4 | | 3 | | 2 | | | 1 | |
| INPUT WATTS | 281.00 | 330.00 | 235.00 | 275.00 | 192.80 | 205.20 | 203.20 | 303 | 189.9 |
| LINE CURRENT: | 1.550 | 1.690 | 1.197 | 1.393 | 1.019 | 1.080 | 1.069 | 1.560 | 1.006 |
| POWER FACTOR | 0.926 | 0.933 | 0.933 | 0.938 | 0.900 | 0.905 | 0.906 | 0.928 | 0.900 |
| BALLAST FACTOR | 0.924 | 0.955 | 1.018 | 1.060 | 0.982 | 0.995 | 0.680 | 0.846 | 1.001 |
| EFFICACY FACTOR | 0.329 | 0.289 | 0.433 | 0.385 | 0.509 | 0.485 | 0.334 | 0.279 | 0.527 |
| EMV/RFI COMPLIANCE | FCC PART 18-A | | | | | | | | |
| SOUND RATING | "A" | | | | | | | | |
| BALLAST TYPE | INSTANT START | | | | | | | | |
| VOLTAGE TRANSIENTS | ANSI C82.11 - 1993/ C62.41 | | | | | | | | |
| THERMAL PROTECTION | AUTOMATIC RESETTING THERMAL SWITCH | | | | | | | | |
| MIN OPERATING TEMP | 0°C (32°F) | | | | | | | | |
| MAX CASE TEMP | 70°C (158°F) | | | | | | | | |
| ENERGY STAR 4.0 | - | | | | | | | | |
| APPROVALS/CLASS | UL/cUL LISTED, CLASS "P", 1 OUTDOOR | | | | | | | | |

MECHANICAL DATA

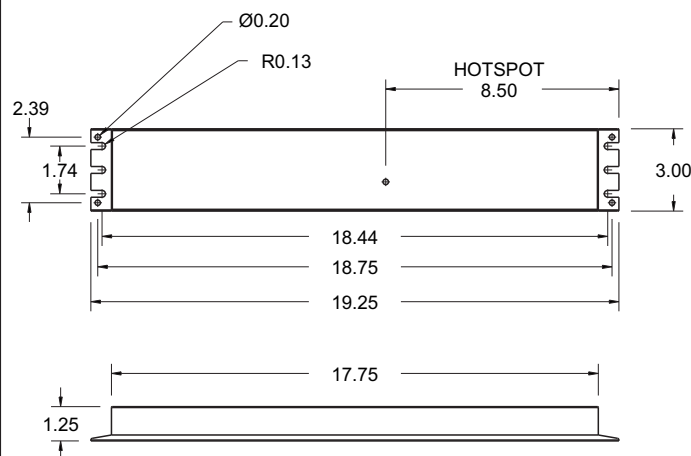

WIRING DIAGRAMS

| WIRE | BLACK | WHITE | RED | BLUE | YELLOW | BROWN |
|-----------------|---------|---------|---------|------|---------|-------|
| LENGTH - INCHES | 24 ± 1" | 24 ± 1" | 48 ± 1" | | 48 ± 1" | |

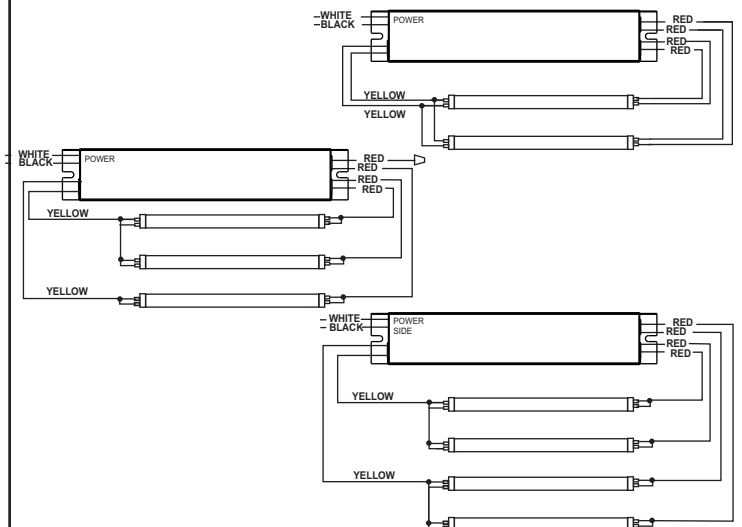

NOTE : This Ballast Case Must Be Grounded

Fulham Co., Inc extends limited warranty only to the original purchaser or to the first user for the period of 3 years from the date of manufacture as indicated by the date code stamped on each product and when properly installed and under normal conditions of use. For additional warranty guide line, please refer to our Complete Product Catalog OR call Customer Service at 1-323-599-5000.

DUE TO A PROGRAM OF CONTINUOUS IMPROVEMENT, FULHAM Co., INC RESERVES THE RIGHT TO MAKE ANY VARIATION IN DESIGN OR CONSTRUCTION TO THE EQUIPMENT DESCRIBED.

Address : 12705 South Van Ness Ave., Hawthorne, CA 90250 Tel.: 1-323-599-5000, Fax.: 1-323-754-9060. Website: www.fulham.com

2006-139 rev A