

Features

- Support DALI-2 dimming mode
- 10-level current output can be realized by DIP-switch
- Soft dimming and flicker-free at any brightness
- Dimming range 1~100%
- Standby power input<0.5W, meets the requirements of ErP certification
- High PF, high efficiency, low THD
- Independent input and output strain relief, stronger wiring
- Intelligent LED hot-plug protection function
- SELV and Class II design, suitable for use outside of the light
- Passed ENEC-TUV,CE,RCM,CCC,DALI-2 and other certifications
- IP20 protection grade, indoor use
- Nominal life-time up to 50,000 h

Interfaces

- DALI-2(DALI-2 DT6)

Functions

- Support central emergency application (dimming normal in DC input)
- Support self-contained emergency application
- Protective features (short-circuit,no-load, hot plug-in protection)

Suitable for lights

- Suitable for lights with independent drivers such as downlights, spotlights, panel lights, etc

Typical applications

- LED indoor lighting
- LED office lighting
- LED commercial lighting





T1A1240100S-50EE

SPECIFICATIONS



- **DALI-2 Constant Current LED Driver**
- **Multiple current selection through dip switch.**
- **Output Current: 550 - 1000mA**
- **Flicker Free: O/P Ripple current < 10%**
- **Output Wattage : 50W Max**
- **Output voltage range of 3-54Vdc**
- **Linear CRCA Cabinet**
- **Suitable For Dry Locations**
- **Application:**
 - Suitable for indoor SELV application
 - Suitable for Linear fixture for Office, Education, Storage area and Retail

General Specifications

Rated Input Voltage	200-240Vac,50/60Hz
Operating Input Voltage Range	180-264Vac,50/60Hz
Input Current	<0.35 @ 230Vac
Input Power	55.5W
Power Factor	>0.95 @ 230Vac/Full Load, >90 @ 230Vac/>50% Load
THD	<15% @ 230Vac/Full Load, THD <20% @ 230Vac/>50% Load
Efficiency (Typical)	88%
Driver Type	Constant Current DALI-2
Output Current	100mA ±5%, 950mA ±5%, 900mA ±5%, 850mA ±5%, 800mA ±5%, 750mA ±5%, 700mA ±5%, 650mA ±5%, 600mA ±5%, 550mA ±5% *Refer DIP switch Table for O/P current selection
Output Voltage Range	3-54Vdc (3-52Vdc @ 950mA, 3-50Vdc @1000mA)
Output Power	50W
Number of Output Channels	1 Channel
Output Type	Class I
Dimming Controller Type	DALI-2
Ambient Operating Temperature Range	-20°C to 60°C
Max. Case Temperature	90°C
Input Surge Protection	2.5KV / 2.5KV
Protections	Input Over Current : Non Resettable (Fuse) Output Short Circuit : Auto Recovery (HICCUP Mode) Output Open Circuit : Auto Recovery (HICCUP Mode) Output Overload : Auto Recovery (HICCUP Mode) Over Temperature : Auto Recovery (HICCUP Mode)
Safety Standards	EN61347-1/2-13, GB19510.1/14, EN62384, IEE1789
Dali Standards	IEC62386-101, 102, 207
Withstand Voltage	I/P-O/P:3750Vac, I/P-FG:1750Vac, O/P-FG:500Vac
Leakage Current	<0.75mA @ 240Vac
Isolation resistance	I/P-O/P:100MΩ / 500Vdc / 25°C / 70% RH
Life	50,000 Hours
Approvals / Class	SELV Equivalent
Warranty	3 Years
Weight	0.230 Kg

Note : Suitable for indoor application only

Fulham extends a limited warranty only to the original purchaser or to the first user for a period of **03 years @ Tc 85°C** from the date of manufacture when properly installed and operated under normal conditions of use. For complete terms and conditions, please reference the Fulham Product Catalog (www.fulham.com). Due to a program of continuous improvement, Fulham reserves the right to make modifications or variations in design or construction to the equipment described. © Fulham Company Limited, All Rights Reserved.

DIP Switch Chart :

Remark: ■ this current is factory default.
 - this Switch is off.

Switching selection sheet								
Pin(W) typ.	Output			Switch				
	Prated(W)	Irated(mA)	Voltage(Vdc)	1	2	3	4	
33.5	29.7	550	<input type="checkbox"/>	3-54	-	ON	ON	ON
36.5	32.4	600	<input type="checkbox"/>	3-54	ON	-	ON	ON
39.5	35.1	650	<input type="checkbox"/>	3-54	-	-	ON	ON
42.5	37.8	700	<input type="checkbox"/>	3-54	-	ON	-	ON
45.5	40.5	750	<input type="checkbox"/>	3-54	-	-	-	ON
48.5	43.2	800	<input type="checkbox"/>	3-54	ON	ON	ON	-
51.5	45.9	850	<input type="checkbox"/>	3-54	-	-	ON	-
54.0	48.6	900	<input type="checkbox"/>	3-54	-	ON	-	-
55.0	49.4	950	<input type="checkbox"/>	3-52	ON	-	-	-
55.5	50.0	1000	<input checked="" type="checkbox"/>	3-50	-	-	-	-

Before use, always check dipswitch settings!

THD vs Load

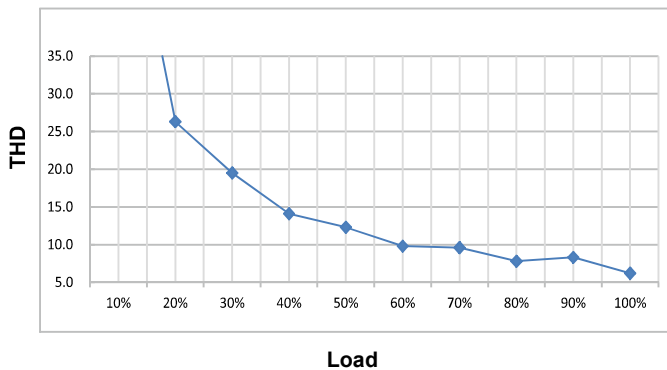

Power Factor vs LOAD

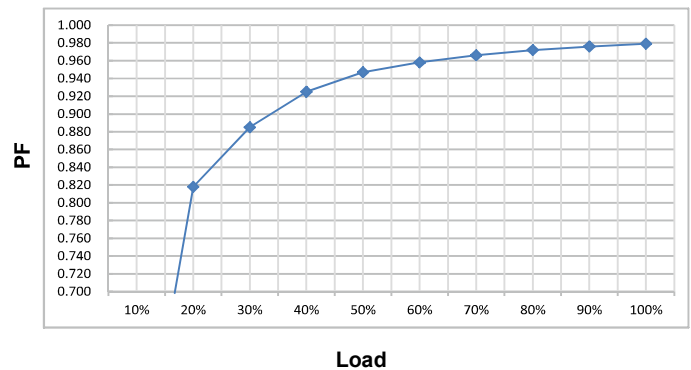

Efficiency vs Load

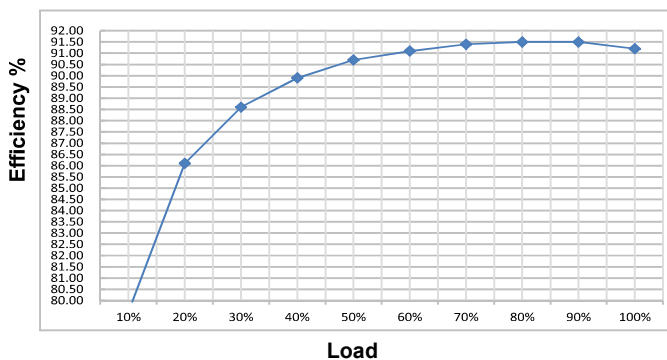

Life Time vs Case Temperature Curve

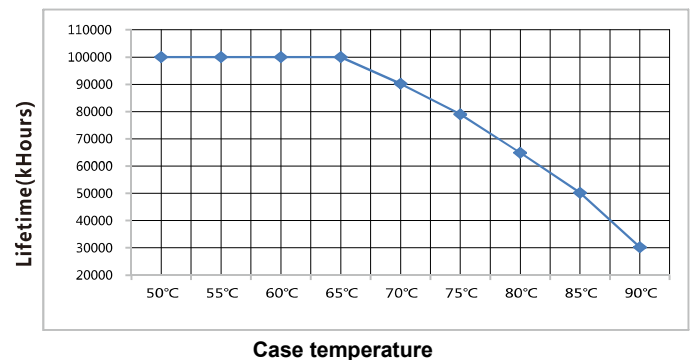

Fulham extends a limited warranty only to the original purchaser or to the first user for a period of **03 years @ Tc 85°C** from the date of manufacture when properly installed and operated under normal conditions of use. For complete terms and conditions, please reference the Fulham Product Catalog (www.fulham.com). Due to a program of continuous improvement, Fulham reserves the right to make modifications or variations in design or construction to the equipment described. © Fulham Company Limited, All Rights Reserved.

DALI dimming application

Wiring diagram

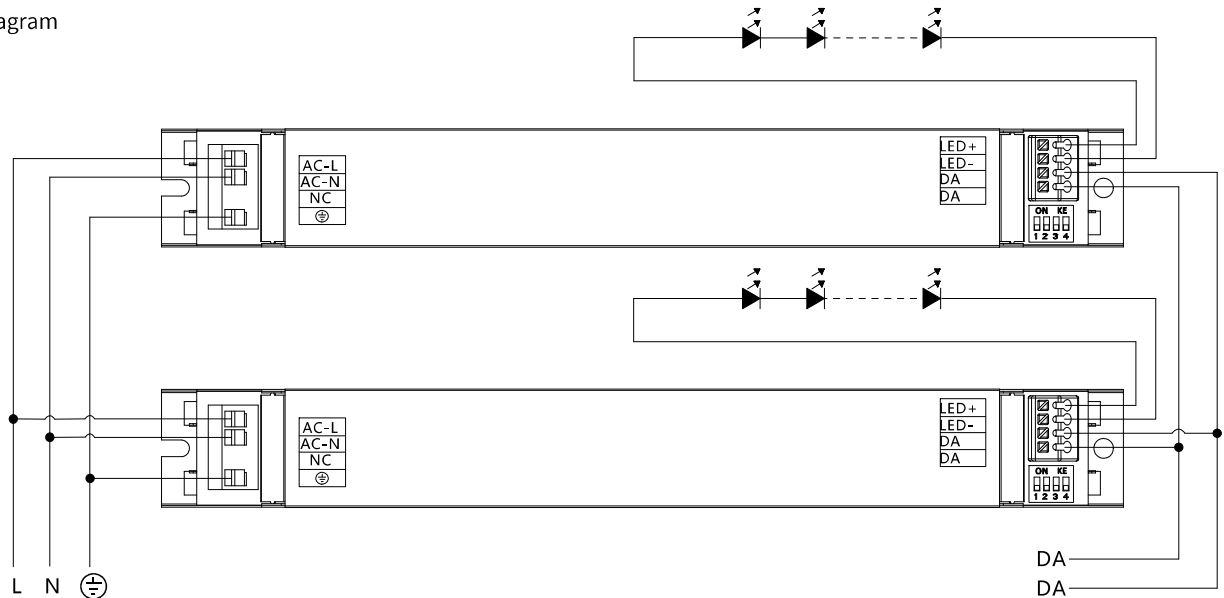

Activating DALI control mode

- After installation according to the wiring diagram of DALI control application, the driver will automatically switch to the DALI control mode after receiving any DALI command.

Remarks:

- Standard DALI control line voltage range: 9.5V to 22.5V, type 16V.
- The two DALI control lines polarity-reversible.
- Max. 64 DALI drivers per DALI control line.
- The maximum distance length of the DALI control line is 300m at $2 \times 1.5\text{mm}^2$.
- DALI bus can be wired together with any mains voltage cables, but separate wiring is recommended.

Wiring distance vs cable size

Cable size	Distance
$2 \times 0.50\text{mm}^2$	max.100m
$2 \times 0.75\text{mm}^2$	max.150m
$2 \times 1.00\text{mm}^2$	max.200m
$\geq 2 \times 1.50\text{mm}^2$	max.300m

Dimming curve

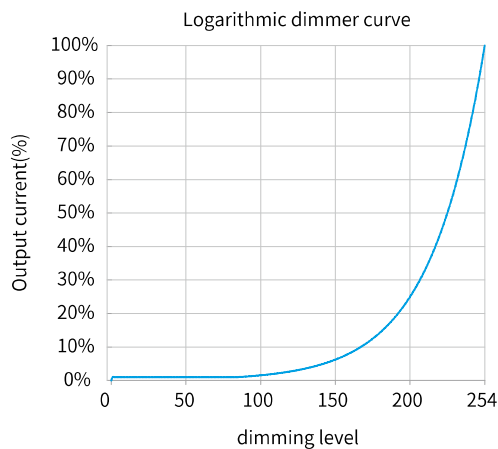

Remarks: The dimming curve can be selected by DALI configuration. The default is logarithmic dimming curve.

Fulham extends a limited warranty only to the original purchaser or to the first user for a period of **03 years @ Tc 85°C** from the date of manufacture when properly installed and operated under normal conditions of use. For complete terms and conditions, please reference the Fulham Product Catalog (www.fulham.com). Due to a program of continuous improvement, Fulham reserves the right to make modifications or variations in design or construction to the equipment described. © Fulham Company Limited, All Rights Reserved.

Mechanical Data :

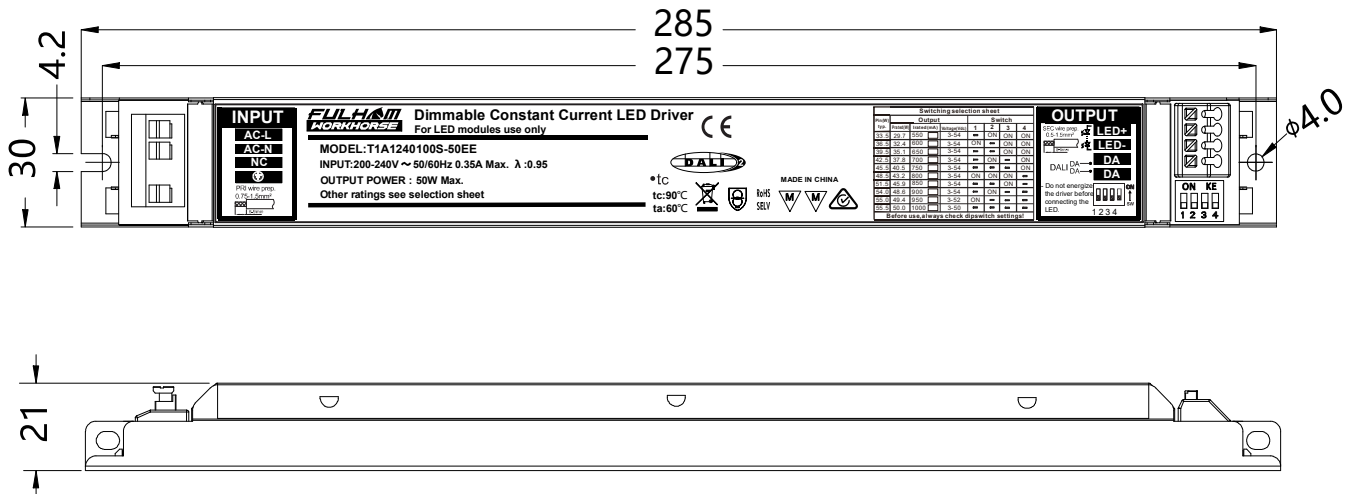

Note : All Dimensions are in mm.

Tolerance=±0.5mm

Packaging

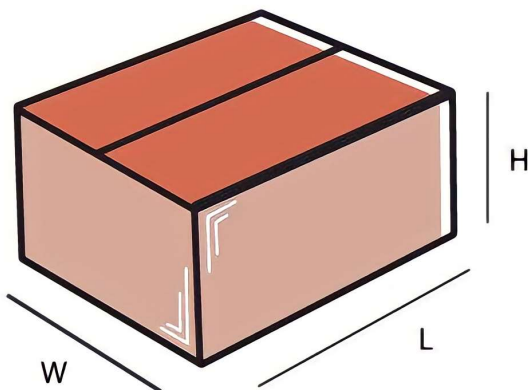

Master carton

OUTER DIMENSION		
L	W	H
355mm	285mm	170mm
Net Weight	Gross Weight	QUANTITY
8.02 kg	9.15 kg	35 pc.

Installation Instructions:

Connect Wires as per details given on the Driver Screen. Keep proper ventilation around the LED Driver and do not stack any object on it. Also a 10-15 cm clearance must be kept when the adjacent device is a heat source. Do not exceed the declared Hot spot temperature(Tc max) under any circumstances.

Fulham extends a limited warranty only to the original purchaser or to the first user for a period of **03 years @ Tc 85°C** from the date of manufacture when properly installed and operated under normal conditions of use. For complete terms and conditions, please reference the Fulham Product Catalog (www.fulham.com). Due to a program of continuous improvement, Fulham reserves the right to make modifications or variations in design or construction to the equipment described. © Fulham Company Limited, All Rights Reserved.