



# TECHNICAL DATA SHEET : ELECTRONIC BALLAST

Project : STANDARD

Type : PROFESSIONAL

Model No : HPY-240-236-IT8-OAF

Remark :

## Model : 2 x 36W BALLAST

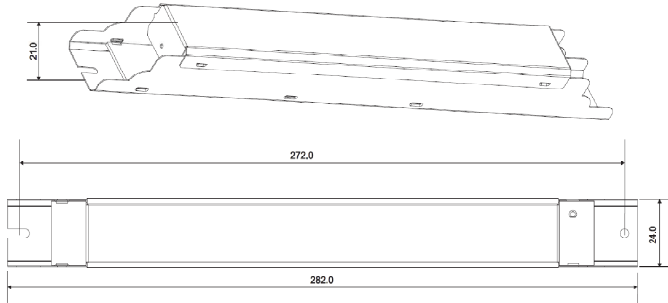

## Input Characteristics

1	Voltage (Un)	240 Vac
2	Operating Voltage Range	140 ~ 277 Vac
3	Frequency (Hz)	50 / 60 Hz
4	Current (A)	0.31 A
5	Wattage (W)	72W
6	Power Factor (PF)	> 0.98 (PPFC)
7	Current Harmonics (Athd)	< 10%
8	Over Current Protection	Yes
9	Surge Withstanding Capacity	Yes
10	Over Voltage Application	@ 320Vac 48Hrs & @ 360Vac 2 Hrs

## Output Characteristics

1	Lamp Types	36W-T8-FTL 40W-T12-FTL 36W-PLL
2	Number of Lamps	2
3	Lamp Connection	Dual Series
4	Single Lamp Operation	No
5	Lamp Current	0.320A
6	Operating Frequency	≥ 40 KHz
7	Ignition Method	RS

## Ballast Characteristics

1	Lamp Current Crest Factor (CCF)	≤ 1.70
2	Ballast Efficiency (BE)	≥ 86%

## Protection Features

1	Deactivated Lamp	Yes
2	Restart or Latching	Latching

## Environmental Operating Details

1	Minimum Lamp Starting Temperature	0°C
2	Max. Ambient Temperature	50°C
3	Max. Case Temperature (Tc)	75°C

## Ordering Information

Sr	Model Number	Description	Case Lot
1	HPY-240-236-IT8-OAF	2x36W T8 <10% THD 2x40W T12 <10% THD 2x36W PLL <10% THD	50

## Mechanical Details

1	Weight	160 gm
2	Case Dimensions	
	Length W/Mount	282 mm
	Center to Center ( CTC )	272 mm
	Width	24 mm
	Height	21 mm
3	Case Material	Metal Case
4	Wiring Diagram	On Screen
5	Input / Output Connections	Connectors Push Type
6	Wires Length & Colors	
	Input ( White & Black )	N/A
	Output ( White )	N/A
	Output ( Gray )	N/A
7	Potting	N/A

## Notes

A High power factor Electronic ballast specially designed for heavy duty use.

### Key features :-

- Slim Design.
- High Voltage withstanding capacity.
- High Surge withstanding capacity
- Long Life.
- High Durability
- Lamp will not Shut down @ high Voltage
- Automatic restart after lamp replacement

Fulham extends a limited warranty only to the original purchaser or to the first user for a period of 2 years from the date of manufacture when properly installed and operated under normal conditions of use. For complete terms and conditions, please reference the Fulham product catalog ([www.fulham.com](http://www.fulham.com))

Due to a program of continuous improvement, Fulham reserves the right to make modifications or variations in design or construction to the equipment described. © Fulham Company Limited, All Rights Reserved.

DOC NUMBER :-FULTDS031  
REV :-1.2  
Date :-01.04.2013