

SPECIFICATION SHEET : WHSG8-UNV-T8SL

This Is An Original Product From Fulham Co., Inc

Description : WORKHORSE Specifier Grade Series Electronic Ballast, Drop In Replacement for Magnetic Ballast, Parallel Lamp Operation, THD Less Than 10%

This Ballast Will Operate Following Lamps.

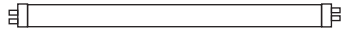

F96T8, F96T8HO

ELECTRICAL DATA (120V APPLICATION)

INPUT VOLT: 120V ± 10%, 50/60Hz									
LAMP WATTS/TYPE	F96T8	F96T8HO	F96T8	-	-	-	-	-	-
LAMPS OPERATED	1		2						
INPUT WATTS	67	95	109						
LINE CURRENT:	0.56	0.79	0.91						
POWER FACTOR	0.99	0.99	0.99						
BALLAST FACTOR	1.15	0.98	0.99						
EFFICACY FACTOR	1.72	1.03	0.90						
THD	5%	5%	5%						
CURRENT CREST FACTOR	< 1.7								
EMI/RFI COMPLIANCE	FCC PART 18-A								
SOUND RATING	" A "								
BALLAST TYPE	INSTANT START								
VOLTAGE TRANSIENTS	ANSI C82.11 - 1993								
INPUT/PROTECTION	FUSE								
OUTPUT/PROTECTION	EOL								
MIN. OPERATING TEMP	0 °C (32 ° F)								
MAX. CASE TEMP	70 °C (158 ° F)								
TYPE "HL" APPROVAL	APPROVED FOR HAZARDOUS LOCATION								
ENERGY STAR 4.0	-								
APPROVALS/CLASS	UL /cUL LISTED, CLASS " P ", 1 OUTDOOR								
REMOTE MOUNTING	18 FT MAX.								

MECHANICAL DATA

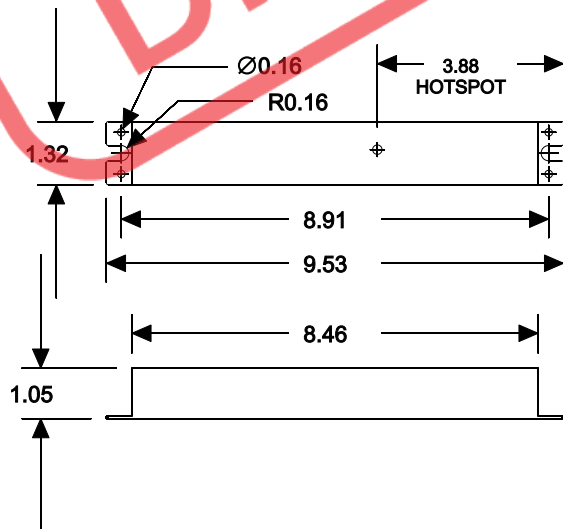

Where : L = Length, W = Width, H = Height

WIRING DIAGRAMS

WIRE	BLACK	WHITE	RED	BLUE	YELLOW	BROWN
LENGTH - INCHES	25 ± 1"	25 ± 1"	79 ± 1"	46 ± 1"		

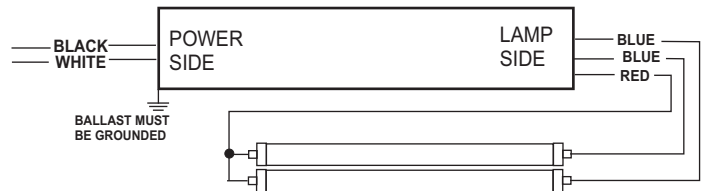

FOR ONE LAMP APPLICATION, CAP ONE BLUE WIRE.

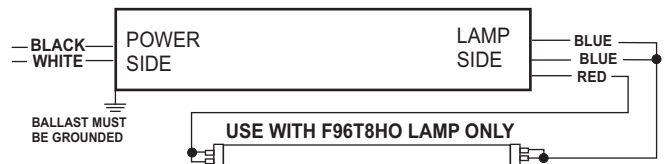

NOTE : This Ballast Case Must Be Grounded

Fulham Co., Inc extends limited warranty only to the original purchaser or to the first user for the period of 5 years from the date of manufacture as indicated by the date code stamped on each product and when properly installed and under normal conditions of use. For additional warranty guide line, please refer to our Complete Product Catalog OR call Customer Service at 1-800-2-Fulham.

DUE TO A PROGRAM OF CONTINUOUS IMPROVEMENT, FULHAM Co., INC RESERVES THE RIGHT TO MAKE ANY VARIATION IN DESIGN OR CONSTRUCTION TO THE EQUIPMENT DESCRIBED.

Address : 12705 South Van Ness Ave., Hawthorne, CA 90250 Tel.: 1-800-2-fulham, Fax.: 1-323-754-9060. Website: www.fulham.com 02-2006-151-1 rev C

SPECIFICATION SHEET : WHSG8-UNV-T8SL

This Is An Original Product From Fulham Co., Inc

Description : WORKHORSE Specifier Grade Series Electronic Ballast, Drop In Replacement for Magnetic Ballast, Parallel Lamp Operation, THD Less Than 10%

This Ballast Will Operate Following Lamps.

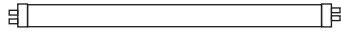

F96T8, F96T8HO

ELECTRICAL DATA (230V APPLICATION)

INPUT VOLT: 230V ± 10%, 50/60Hz									
LAMP WATTS/TYPE	F96T8	F96T8HO	F96T8	-	-	-	-	-	-
LAMPS OPERATED	1		2						
INPUT WATTS	66	93	107						
LINE CURRENT:	0.30	0.41	0.47						
POWER FACTOR	0.98	0.98	0.99						
BALLAST FACTOR	1.15	0.98	0.99						
EFFICACY FACTOR	1.73	1.05	0.92						
THD	8%	8%	8%						
CURRENT CREST FACTOR	< 1.7								
EMI/RFI COMPLIANCE	FCC PART 18-A								
SOUND RATING	" A "								
BALLAST TYPE	INSTANT START								
VOLTAGE TRANSIENTS	ANSI C82.11 - 1993								
INPUT/PROTECTION	FUSE								
OUTPUT/PROTECTION	EOL								
MIN. OPERATING TEMP	0 °C (32 ° F)								
MAX. CASE TEMP	70 °C (158 ° F)								
TYPE "HL" APPROVAL	APPROVED FOR HAZARDOUS LOCATION								
ENERGY STAR 4.0	-								
APPROVALS/CLASS	UL /cUL LISTED, CLASS " P ", 1 OUTDOOR								

MECHANICAL DATA

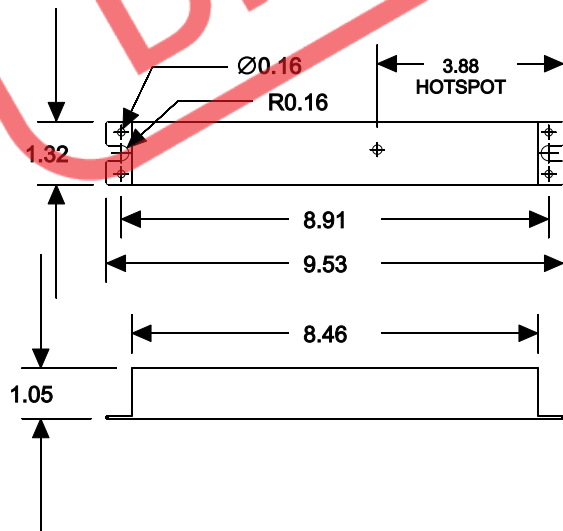

Where : L = Length, W = Width, H = Height

WIRING DIAGRAMS

WIRE	BLACK	WHITE	RED	BLUE	YELLOW	BROWN
LENGTH - INCHES	25 ± 1"	25 ± 1"	79 ± 1"	46 ± 1"		

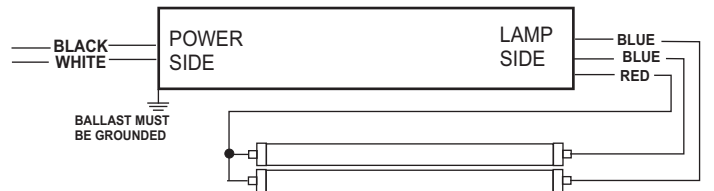

FOR ONE LAMP APPLICATION, CAP ONE BLUE WIRE.

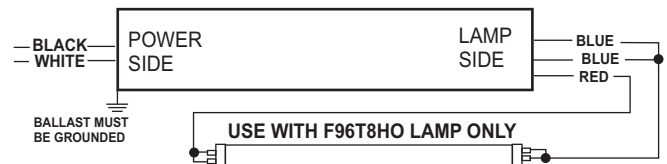

NOTE : This Ballast Case Must Be Grounded

Fulham Co., Inc extends limited warranty only to the original purchaser or to the first user for the period of 5 years from the date of manufacture as indicated by the date code stamped on each product and when properly installed and under normal conditions of use. For additional warranty guide line, please refer to our Complete Product Catalog OR call Customer Service at 1-800-2-Fulham.

DUE TO A PROGRAM OF CONTINUOUS IMPROVEMENT, FULHAM Co., INC RESERVES THE RIGHT TO MAKE ANY VARIATION IN DESIGN OR CONSTRUCTION TO THE EQUIPMENT DESCRIBED.

Address : 12705 South Van Ness Ave., Hawthorne, CA 90250 Tel.: 1-800-2-fulham, Fax.: 1-323-754-9060. Website: www.fulham.com 02-2006-151-2 rev C

SPECIFICATION SHEET : WHSG8-UNV-T8SL

This Is An Original Product From Fulham Co., Inc

Description : WORKHORSE Specifier Grade Series Electronic Ballast, Drop In Replacement for Magnetic Ballast, Parallel Lamp Operation, THD Less Than 10%

This Ballast Will Operate Following Lamps.

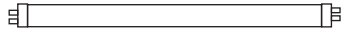

F96T8, F96T8HO

ELECTRICAL DATA (277V APPLICATION)

INPUT VOLT: 277V ± 10%, 50/60Hz									
LAMP WATTS/TYPE	F96T8	F96T8HO	F96T8	-	-	-	-	-	-
LAMPS OPERATED	1		2						
INPUT WATTS	66	93	107						
LINE CURRENT:	0.25	0.34	0.39						
POWER FACTOR	0.96	0.98	0.98						
BALLAST FACTOR	1.15	0.98	0.99						
EFFICACY FACTOR	1.73	1.05	0.92						
THD	10%	9%	9%						
CURRENT CREST FACTOR	< 1.7								
EMI/RFI COMPLIANCE	FCC PART 18-A								
SOUND RATING	" A "								
BALLAST TYPE	INSTANT START								
VOLTAGE TRANSIENTS	ANSI C82.11 - 1993								
INPUT/PROTECTION	FUSE								
OUTPUT/PROTECTION	EOL								
MIN. OPERATING TEMP	0 °C (32 ° F)								
MAX. CASE TEMP	70 °C (158 ° F)								
TYPE "HL" APPROVAL	APPROVED FOR HAZARDOUS LOCATION								
ENERGY STAR 4.0	-								
APPROVALS/CLASS	UL /cUL LISTED, CLASS " P ", 1 OUTDOOR								

MECHANICAL DATA

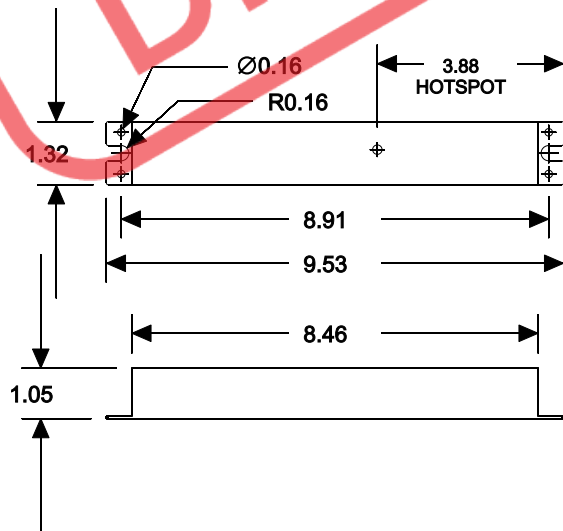

Where : L = Length, W = Width, H = Height

WIRING DIAGRAMS

WIRE	BLACK	WHITE	RED	BLUE	YELLOW	BROWN
LENGTH - INCHES	25 ± 1"	25 ± 1"	79 ± 1"	46 ± 1"		

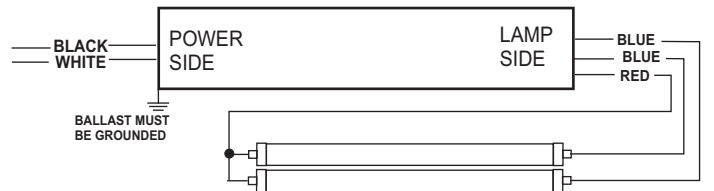

FOR ONE LAMP APPLICATION, CAP ONE BLUE WIRE.

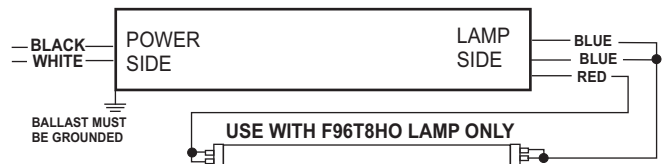

USE WITH F96T8HO LAMP ONLY

NOTE : This Ballast Case Must Be Grounded

Fulham Co., Inc extends limited warranty only to the original purchaser or to the first user for the period of 5 years from the date of manufacture as indicated by the date code stamped on each product and when properly installed and under normal conditions of use. For additional warranty guide line, please refer to our Complete Product Catalog OR call Customer Service at 1-800-2-Fulham.

DUE TO A PROGRAM OF CONTINUOUS IMPROVEMENT, FULHAM Co., INC RESERVES THE RIGHT TO MAKE ANY VARIATION IN DESIGN OR CONSTRUCTION TO THE EQUIPMENT DESCRIBED.

Address : 12705 South Van Ness Ave., Hawthorne, CA 90250 Tel.: 1-800-2-fulham, Fax.: 1-323-754-9060. Website: www.fulham.com 02-2006-151-3 rev C