

TMM140045ACXXXA

Constant Current LED Round Module

- High density, high brightness chip array for use in Class 2 Circular applications
- Constant current for maximum efficacy
- Available in standard CCT's
- Dimmable when used with a dimmable driver
- Integral thermal feedback protection to safeguard against overheating
- Suitable for DLC and Energy Star compliant luminaires
- 80 CRI standard and 90 CRI available

General Ratings

Max Lumen Output @ Max Current	5000 lumens at 4000K / 80 CRI*
Max Current Input	1400 mA
Nominal DC Power Consumption @ Max Current	45W
Nominal Operating Voltage @ Max Current	32V ± 4V DC
Thermal Feedback Protection	Yes; 0-10V Dimmable Driver Required**
Beam Angle	120°
CRI	80, 90
Operating Ambient Temperature Range (Ta)	-35 to +40°C / -31 to +104°F
Maximum Module Case Temperature (Tc)	+85°C
Estimated Lumen Maintenance (L70)	>50,000 hours at max Tc
Color Consistency	Binning per ANSI C78.377-2008; 7 SDCM
Overall Size	3" diameter x 0.17" H
Material / Weight	MCPCB / 32g
Maximum Screw Installation Torque	35 inch - ounces
Safety/Compliance	cURus (File # E351548) Class 2 Lighting System RoHS Compliant; CE
Warranty	5 years with suitable Fulham LED Drivers and thermal feedback utilization

* At Tc mod = 25°C

** If external dimming is required, a passive 0-10V dimmer must be used.
See more on Thermal Feedback Protection use on Page 3

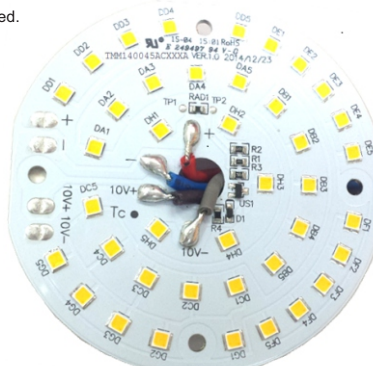

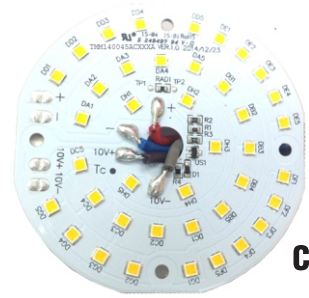

TMM140045ACXXXA

Part Numbering Matrix

T M M 140 045 A C 8 27 A

CRI	Color Temperature
8* = 80	27 = 2700K
9 = 90	30* = 3000K
	35 = 3500K
	40* = 4000K
	50 = 5000K

*Indicates standard module options. All others are built to order.

Electrical Specifications

LED Module Part Number	Number of LED	Input Current	Abs. Max Forward Voltage	Nom. Forward Voltage	Nom. Rated Power
TMM140045ACxxxA	40	1400mA**	36 VDC***	32 VDC	45W
		1050mA	35 VDC***	31 VDC	33.5W

** Indicates maximum rated current. Modules may be operated at a current less than or equal to this value. Reference Current vs. Rel. Lum. Flux Table to calculate estimate lumen output at lesser currents.

*** Absolute maximum forward voltage was not used in calculating nominal rated power. Data is provided to assist in selecting proper LED driver.

Electrical and Optical Specifications

LED Module Part Number	Color Temperature	Nominal Luminous Flux @ 1400mA/90CRI	Nominal Luminous Flux @ 1400mA/80CRI	Efficacy @80CRI
TMM140045ACx27A	2700K	3450 lumens	4350 lumens	96 lm/W
TMM140045ACx30A	3000K	3750 lumens	4650 lumens	103 lm/W
TMM140045ACx35A	3500K	3925 lumens	4800 lumens	106 lm/W
TMM140045ACx40A	4000K	4000 lumens	5000 lumens	111 lm/W
TMM140045ACx50A	5000K	4300 lumens	5350 lumens	118 lm/W

Current vs Relative Luminous Flux Table

Forward Current	Lumen Multiplier
1400mA	1.0
1050mA	0.8

- 1) Electrical and optical specifications are based on Tc mod = 25°C.
- 2) Standard lumen output and efficacy is calculated for standard options. Reference CCT vs Lumen Output chart for lumen ratio calculation.
- 3) Specifications are subject to change without notice.

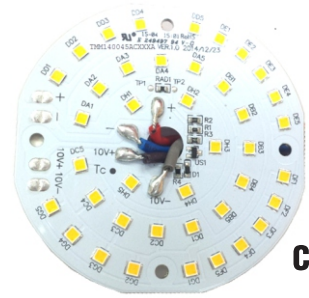

TMM140045ACXXA

Mechanical Drawings

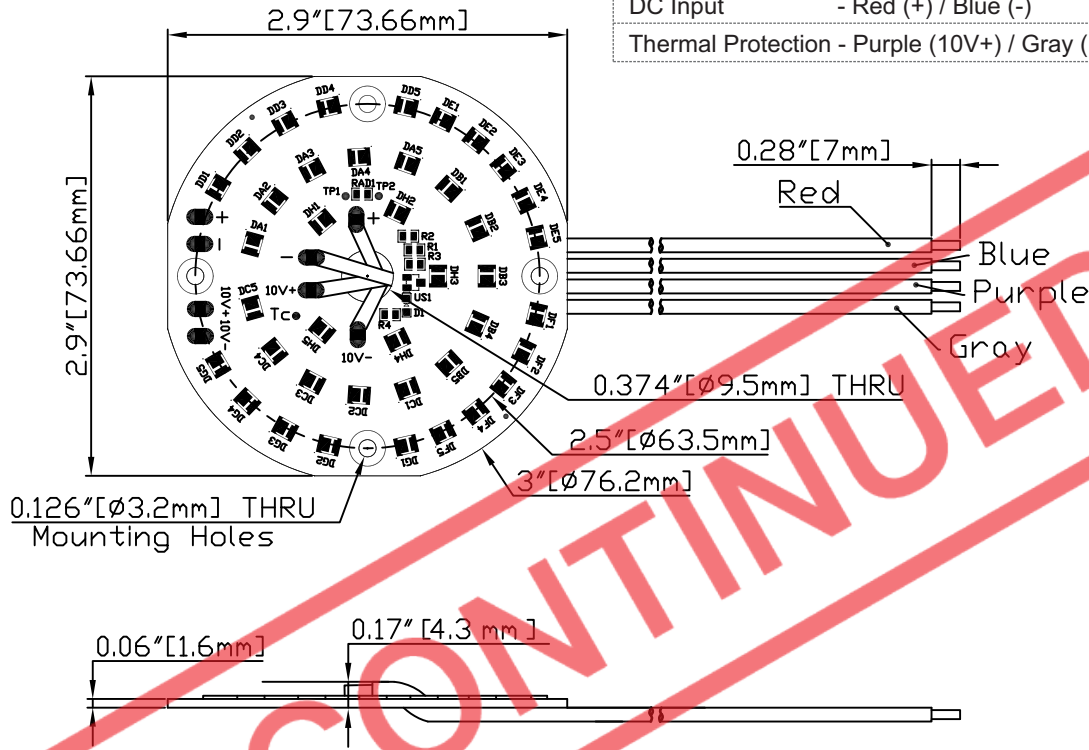

Wire Function	- Color (Polarity)	Wire Length
DC Input	- Red (+) / Blue (-)	8 inches
Thermal Protection	- Purple (10V+) / Gray (10V-)	8 inches

Thermal Specifications

	LED Module
Storage Temperature Range	-35 to 100°C
Operating Ambient Temperature Range	-35 to 40°C
Maximum Case Temperature (Tc)	85°C

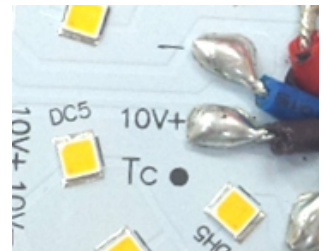

Thermal Feedback Protection

1. A suitable heat sink is required. The Tc point on the module must be used to verify that the temperature remains below the maximum specified Tc.
2. Thermal Feedback Protection works by connecting the 10V+ and 10V- wires of the module to a 0-10V port on a dimmable driver.
3. When Tc exceeds safe level, the Thermal Feedback Protection will be activated. The diagram on the right shows a typical current curve versus Tc when connecting with a Fulham 0-10V dimmable driver.

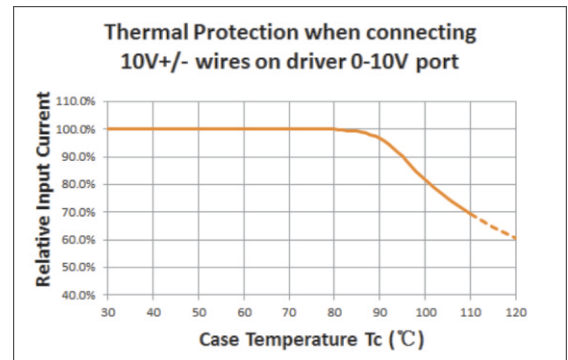

NOTE:

1. Different drivers may have different dimming curves, which can lead to a different current curve when the thermal feedback protection is in operation.
2. A +/-10°C tolerance is allowed to account for the varying of the starting protection Tc due to the NTC tolerance and different driver dimming curve.

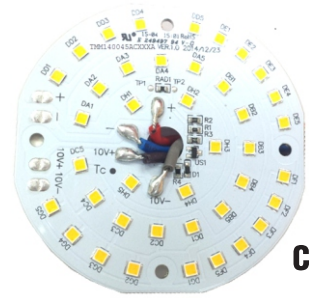

TMM140045ACXXA

Fastening Notes

- If fastening by screw hole, use any screw with diameter less than 0.125 in (3.2mm). Use all available screw holes to ensure good contact between back side of module and mounting surface. Refer to max specified torque for installation. Suggested screw sizes: #5 or M3 Pan Head screw.

Environmental Rating

- Modules are rated for dry locations, unless option for conformal coating is requested.
- Conformal coating is acrylic based and rated for Environment and Moisture Protection per IPC-CC-830.

Electrostatic Sensitive Product (ESD)

- Fulham LED products should be handled with proper measures to protect against any potential ESD damage.
- When servicing, personnel should be ground and direct contact with LED should be avoided.

Thermal Management

- Proper thermal management should be employed to ensure life and reliability of product.
- Use of thermal grease, paste, pad, or other material interface is highly recommended.
- A referenced heat sink from Glacial Light: Model FR091 or equivalent heat sinks from other sources
 - Note: Above heat sink may not be suitable for all conditions. User is advised to perform its own thermal and mechanical analysis to ensure module Spec. requirements are met. Below are references to some heat sink suppliers. Fulham claims no warranties for these references:
 - Glacial: <http://www.glaciallight.com/products/skd-cold-forging.htm>
 - AAVID: <http://www.aavid.com/product-group/extrusions/search>
 - Wakefield: <http://www.wakefield-vette.com/>.



Polarity Notes

- Modules are polarity sensitive.
- Ensure that "positive" from LED Driver is connected to "positive" of LED modules and that "negative" from LED Driver is connected to "negative" of LED modules.
- Polarities of modules are marked with "+" for positive and "-" for negative.

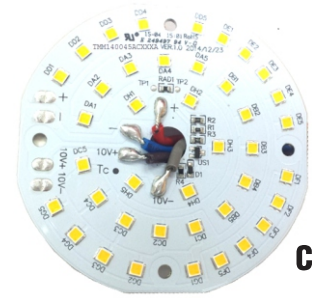

TMM140045ACXXA

Color and Binning

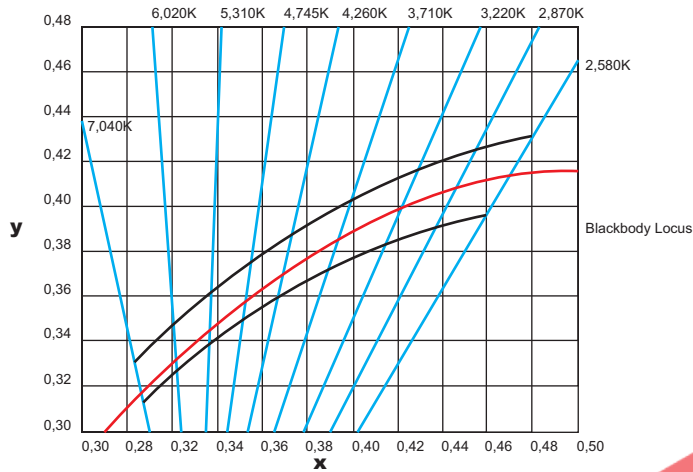

Ref. Nichia
Chromaticity Diagram for ANSI bins
For reference only. For more detailed info, contact factory.

Optical Spectrum***

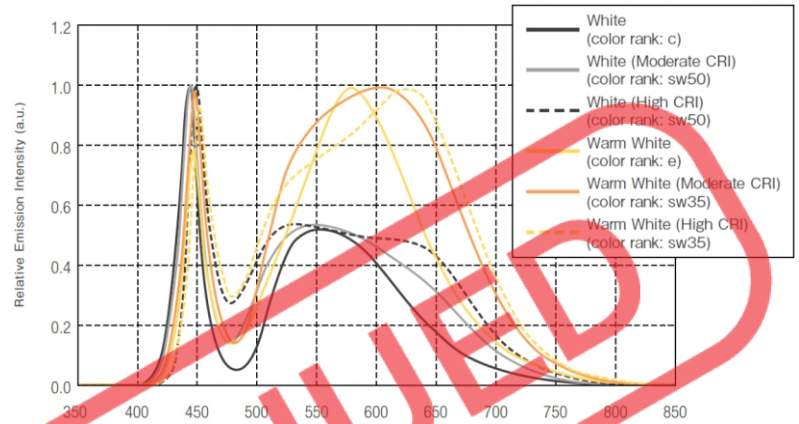

*** Value varies depending on product type and color rank
Ref. Nichia
LED Catalogue 2013
For reference only. For more detailed info, contact factory.

Thermal De-Rating

Ambient Temperature (Ta)	Thermal De-rating Multiplier
25°C	1
30°C	0.991
35°C	0.989
40°C	0.980
45°C	0.975
50°C	0.970
55°C	0.960
60°C	0.950

Ref. Nichia
LED757 Spec Sheet
For reference only. For more detailed info, contact factory.

CCT vs Luminous Flux

CCT	Luminous Flux Ratio
2700K	0.87
3000K	0.93
3500K	0.96
4000K	1.00
5000K	1.07

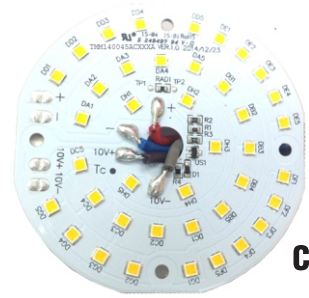

TMM140045ACXXA

Compatible Fulham LED Drivers

Fulham Part Number	Driver Description	# of Modules/Driver
T1M1UNV1400-60L	1400 mA, 60W CC Driver, Universal Input, 0-10V dimmable	1
T1UNV1400-60L	1400 mA, 60W CC Driver, Universal Input	1
T1A1UNV105P-60E	250~1050 mA Programmable, 60W CC Driver, Universal Input, DALI	1
T1M1UNV105P-60F	250~1050 mA Programmable, 60W CC Driver, Universal Input, 0-10V dimmable	1

NOTE:

1. Subject to rated loading conditions.
2. Modules are polarity sensitive. Ensure that "positive" from LED Driver is connected to "positive" of LED modules and that "negative" from LED Driver is connected to "negative" of LED modules.
3. List is subject to change without notice.
4. Refer to below wiring diagram for more information

Wiring Diagram

I. Non-Dimmable; No Thermal Feedback Protection

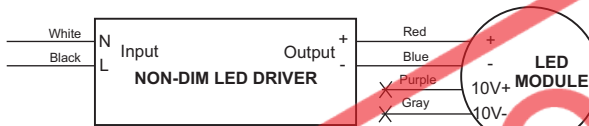

Leave 10V+/- wires on the module not connected.

III. Dimmable; No Thermal Feedback Protection

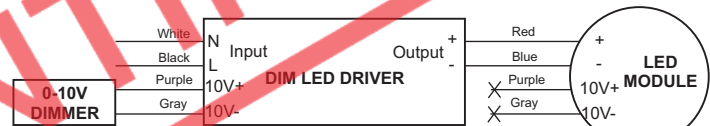

Dimmable driver can be Triac, 0-10V or any other types.
Connect dimmer only to the dimmable driver.
DO NOT connect any dimmer directly to the module 10V+/- wires.

II. Non-Dimmable; Thermal Feedback Protection (Recommended)

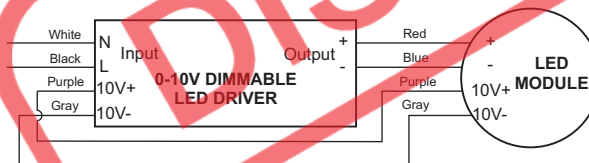

Connect 10V+/- wires on the module to 0-10V port on a dimmable driver

IV. Dimmable; Thermal Feedback Protection

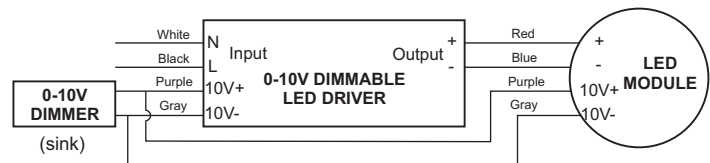

Connect 10V+/- wires on the module to 0-10V port on a dimmable driver together with a passive 0-10V dimmer.
Dimming level depends on the lower voltage signal between the dimmer and the module.