

SPECIFICATION SHEET : PET-120-12-60W

This Is An Original Product From Fulham Co., Inc

Description : PONY ET Series, High Frequency Electronic, Short Circuit, Over Load &, Thermal Protection. Dimming Capability. Operates Mr16 & MR 11 Lamps.

This Ballast Will Operate Following Lamps.



MR11



MR16

ELECTRICAL DATA

INPUT VOLT: 120V ± 10%, 50/60Hz							
LAMP WATTS/TYPE	20MR11	20MR16	35MR16	50MR16	20+20MR11 OR 16	20+35MR16	-
LAMPS OPERATED	1	1	1	1	1	1	
MAX LOAD	60W MAX.						
INPUT CURRENT:	0.60AMP MAX.						
POWER FACTOR	0.950						
MIN LOAD W/O DIMMER	10W						
MIN LOAD WITH DIMMER	20W						
CURRENT THD	20%						
VOLTAGE THD	5%						
EMI/RFI COMPLIANCE	FCC PART 18-A (Non-Consumer)						
SOUND RATING	" A "						
DIMMER CAPABILITY	YES						
VOLTAGE TRANSIENTS	ANSI 62.41						
PROTECTION	AUTO RESET						
MIN. OPERATING TEMP	25 °C (77 °F)						
MAX. CASE TEMP	90°C (194 °F)						
APPROVALS/CLASS	UR /cUR RECOGNIZED COMPONENT, CLASS 2						

MECHANICAL DATA

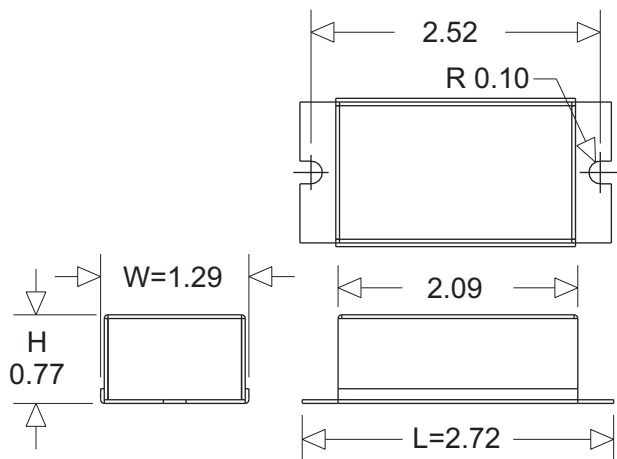

Where : L = Length, W = Width, H = Height

WIRING DIAGRAMS

WIRE	BLACK	WHITE	RED	BLUE	YELLOW	BROWN
LENGTH - INCHES	6 ± 1"	6 ± 1"		6 ± 1"		

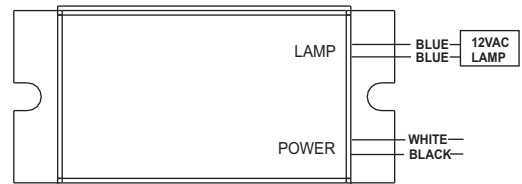

Fulham Co., Inc extends limited warranty only to the original purchaser or to the first user for the period of 2 years from the date of manufacture as indicated by the date code stamped on each product and when properly installed and under normal conditions of use. For additional warranty guide line, please refer to our Complete Product Catalog OR call Customer Service at 1-323-599-5000.

DUE TO A PROGRAM OF CONTINUOUS IMPROVEMENT, FULHAM Co., INC RESERVES THE RIGHT TO MAKE ANY VARIATION IN DESIGN OR CONSTRUCTION TO THE EQUIPMENT DESCRIBED.

Address : 12705 South Van Ness Ave., Hawthorne, CA 90250 Tel.: 1-323-599-5000, Fax.: 1-323-754-9060. Website: www.fulham.com