



SPECIFICATION SHEET : **FEP-230-600-L-10**

This Is An Original Product From Fulham Co., Inc

Description : Sun Horse electronic ballast developed for use with UV & tanning lamp applications

This Ballast Will Operate Following Lamps.



**3 OR 4 F59T12HO / F72T12HO / F79T12HO
2 F72T12VHO / F79T12VHO**

ELECTRICAL DATA (230V APPLICATION)

INPUT VOLT: 230V ± 10%, 50/60Hz						
LAMP WATTS/TYPE	F59T12HO 85W	F72T12HO 100W	F59T12HO 85W	F72T12HO 100W	F72T12VHO 160W	F79T12VHO 200W
LAMPS OPERATED	4		3		2	
INPUT WATTS	273.1W	311.2W	229.2W	260.5W	247.4W	301.5W
LINE CURRENT:	1.299A	1.467A	1.104A	1.242A	1.189A	1.425A
POWER FACTOR	0.914	0.922	0.902	0.911	0.904	0.919
BALLAST FACTOR	0.836	0.841	0.936	0.924	0.788	0.785
EFFICACY FACTOR	0.306	0.270	0.408	0.355	0.318	0.260
EMI/RFI COMPLIANCE	FCC PART 18-A					
SOUND RATING	" A "					
BALLAST TYPE	INSTANT START					
VOLTAGE TRANSIENTS	ANSI C82.11 - 1993 / C62.41					
THERMAL PROTECTION	AUTOMATIC RESETTING THERMAL SWITCH					
MIN. OPERATING TEMP	0 °C (32 °F)					
MAX. CASE TEMP	70 °C (158 °F)					
ENERGY STAR 4.0	-					
APPROVALS/CLASS	UL /cUL LISTED, CLASS " P ", 1 OUTDOOR					

MECHANICAL DATA

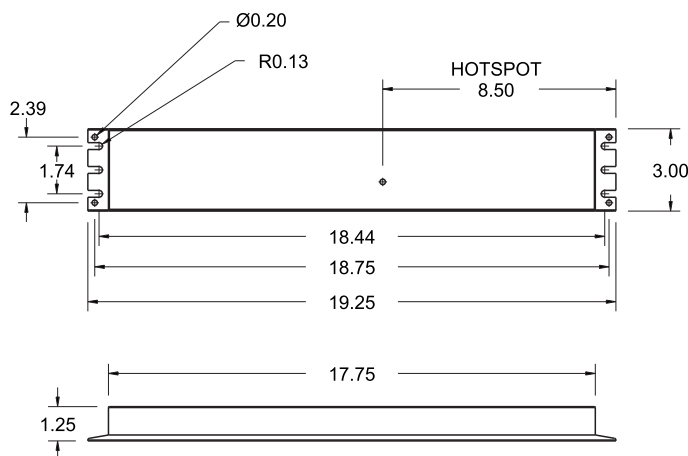

Where : L = Length, W = Width, H = Height

WIRING DIAGRAMS

WIRE	BLACK	WHITE	RED	BLUE	YELLOW	BROWN
LENGTH - INCHES	72 ± 1"	72 ± 1"	120 ± 1"		120 ± 1"	

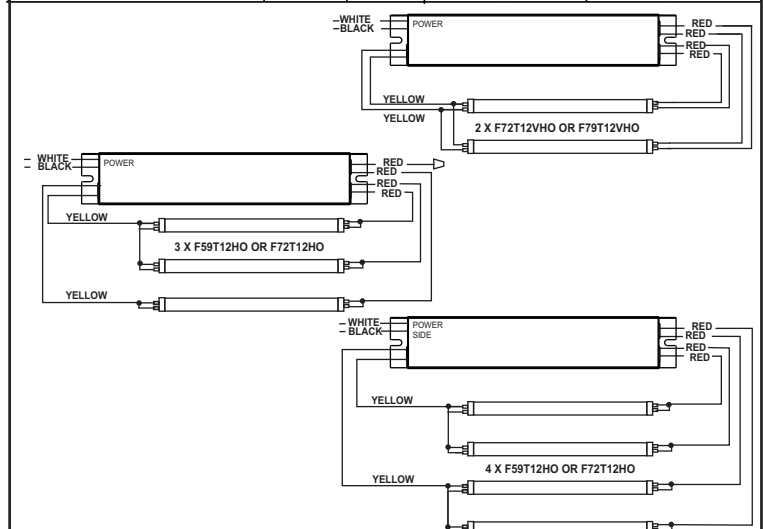

NOTE : This Ballast Case Must Be Grounded

Fulham Co., Inc extends limited warranty only to the original purchaser or to the first user for the period of 3 years from the date of manufacture as indicated by the date code stamped on each product and when properly installed and under normal conditions of use. For additional warranty guide line, please refer to our Complete Product Catalog OR call Customer Service at 1-323-599-5000.

DUE TO A PROGRAM OF CONTINUOUS IMPROVEMENT, FULHAM Co., INC RESERVES THE RIGHT TO MAKE ANY VARIATION IN DESIGN OR CONSTRUCTION TO THE EQUIPMENT DESCRIBED.

Address : 12705 South Van Ness Ave., Hawthorne, CA 90250 Tel.: 1-323-599-5000, Fax.: 1-323-754-9060. Website: www.fulham.com 2009-547 rev